



**DOWNLOAD THE LATEST  
INSTALL MANUALS AT  
[www.bddiesel.com](http://www.bddiesel.com)**



# Sway Bar End Links

For 2000-2012 Dodge RAM 2500/3500

<b>1032050</b>	<b>Dodge 2000-09</b>
<b>1032051</b>	<b>Dodge 2010-12</b>



**NOTE** Does not fit the Dodge PowerWagon



**PLEASE READ ALL INSTRUCTIONS BEFORE INSTALLATION**

## Tools Required

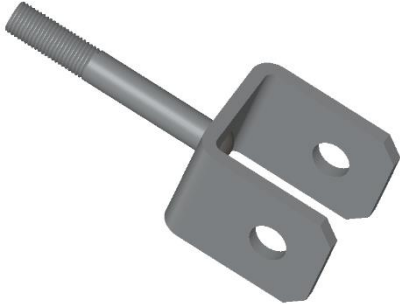

- PRESS OR VISE
- SOCKET SET
- TORQUE WRENCH
- DRILL
- 9/16" DRILL BIT
- WRENCH SET

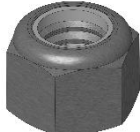
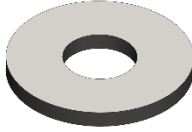
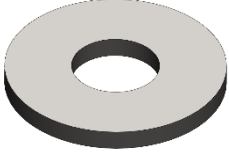

## Kit Contents for 1032050

1312050	1312060	1312051
		
<p align="center"><b>CAST LINK</b></p>	<p align="center"><b>U BRACKET</b></p>	<p align="center"><b>BUSHING KIT</b></p>
<p align="center"><b>Qty: 2</b></p>	<p align="center"><b>Qty: 2</b></p>	<p align="center"><b>Qty: 1</b></p>

1312055	1302034	1312058	1312059	1302035	1302037
					
<p align="center">M14-75mm BOLT</p>	<p align="center">M14-80mm BOLT</p>	<p align="center">M14 NUT</p>	<p align="center">7/16" NUT</p>	<p align="center">M14 WASHER</p>	<p align="center">9/16" WASHER</p>
<p align="center"><b>Qty: 2</b></p>	<p align="center"><b>Qty: 2</b></p>	<p align="center"><b>Qty: 4</b></p>	<p align="center"><b>Qty: 2</b></p>	<p align="center"><b>Qty: 6</b></p>	<p align="center"><b>Qty: 4</b></p>

**Kit Contents for 1032051**

1312050	1312061	1312062
		
CAST LINK Qty: 2	U BRACKET Qty: 2	BUSHING KIT Qty: 1

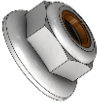
FT-11113736	FT-11113737	FT-11634738	FT-0167034
			
M14-75mm BOLT Qty: 2	M14-80mm BOLT Qty: 2	M14 NUT NYLOC Qty: 4	1/2" -13 NUT NYLOC Flange Qty: 2

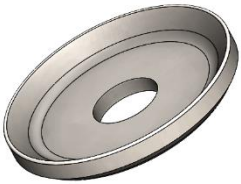
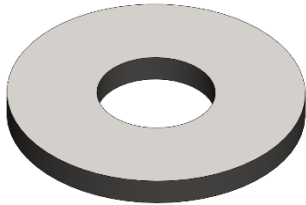
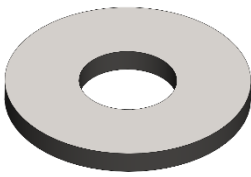
1312063	1312065	FT-11103698
		
WASHER 2010-2012 Qty: 4	WASHER 9/16 1.5 OD Qty: 4	WASHER M14 Qty: 2

## Procedure

1. Block wheels to prevent the vehicle from rolling. Lift and support the front axle and remove the front wheels.
2. Remove stock driver/passenger sway bar end links. Using a (TABLE A) socket on the sway bar side and a (TABLE B) socket on the axle side.

### SWAY BAR CONNECTION (TABLE A)

15 mm	2000-02 / 06-09
16 mm	2003-05
18 mm	2010-12

### AXLE CONNECTION (TABLE B)

15 mm	2003-05
18 mm	2000-02
21 mm	2006-12

**NOTE: On years 2000-2005 you may need to drill the axle mount to 14mm to fit the new hardware if not already modified.**

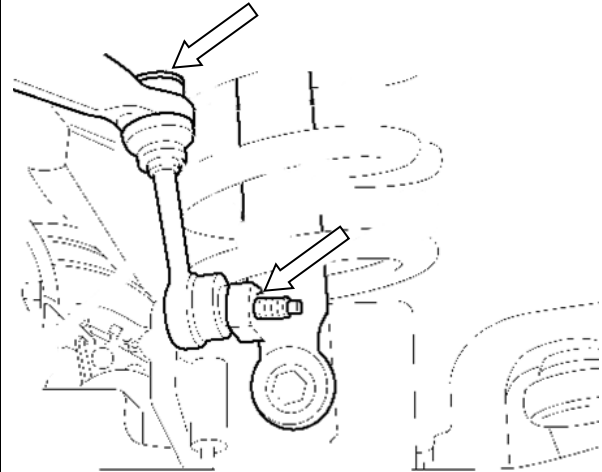

3. Lubricate (2) Polyurethane bushings with the supplied lubrication and press into cast link (1312050) using an arbor press. Then insert steel bushings into the assembly.

Complete steps 3 & 4 for both cast links.

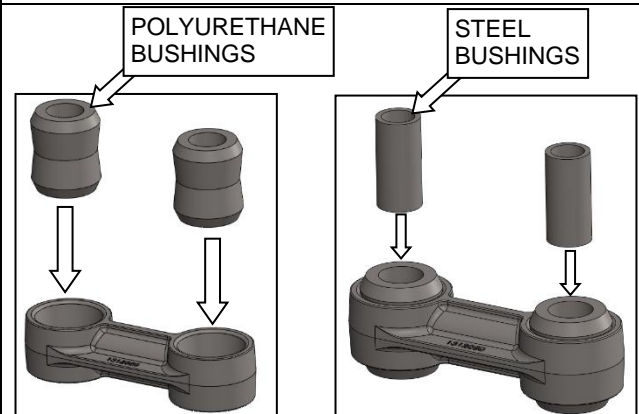

4. Install sway bar u-bracket assembly onto the cast rod with the supplied bolt, two flat washers and a Nylock nut. Leave loose to allow movement.

2000-2009 uses part numbers: 1312060, 1312055, 1302035, 1312058

2010-2012 uses part numbers: 1312061, FT-11113736, FT-11103698, FT-11634738

### 2000-2009 Assembly

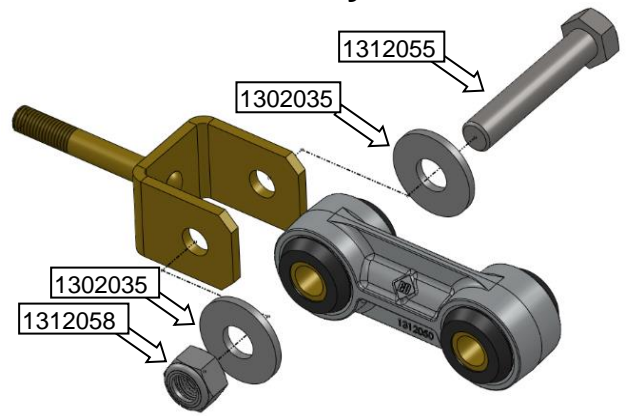

### 2010-2012 Assembly

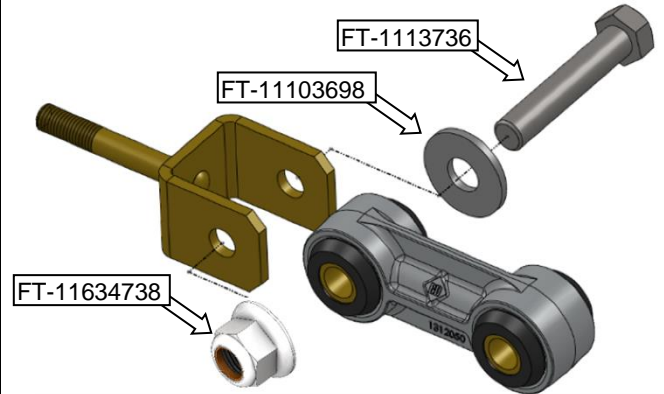

## **Complete steps 5-8 for the driver's side and Passenger side**

5. Slide one formed washer and bushing from the bushing kit onto the u-bracket (note orientation of bushing & washer).

Install u bracket assembly into sway bar then slide on an additional bushing then washer and Nylock nut (1312059 for 2000-2009 or FT-0167034 for 2010-2012) tighten finger tight.

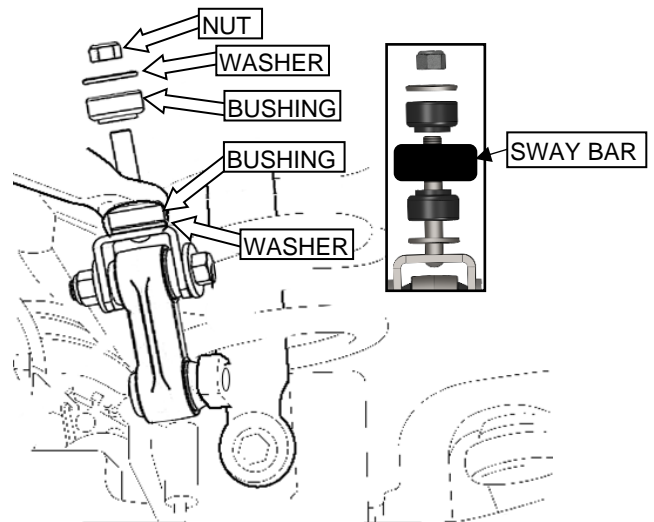

6. Assemble the end link using the two supplied washers and bolt. Then slide the assembly into the axle mount and secure into position using the supplied washer and Nylock nut and tighten finger tight.

See figure (right) for assembly details.

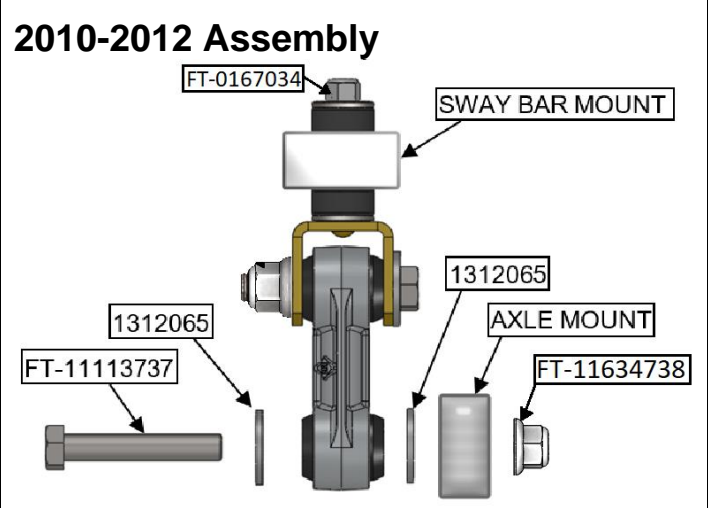
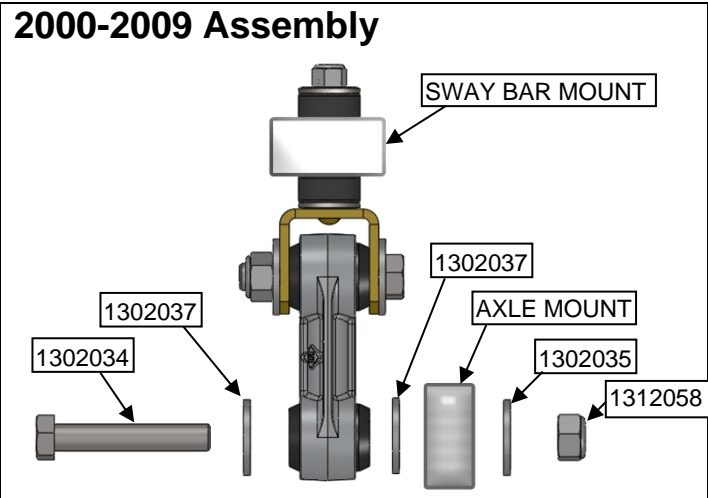

7. Center U-bracket rod in the sway bar and torque Nylock nut 10-12 ft/lbs.

Use a 16mm socket for 2000-2009  
Use a 19mm socket for 2010-2012

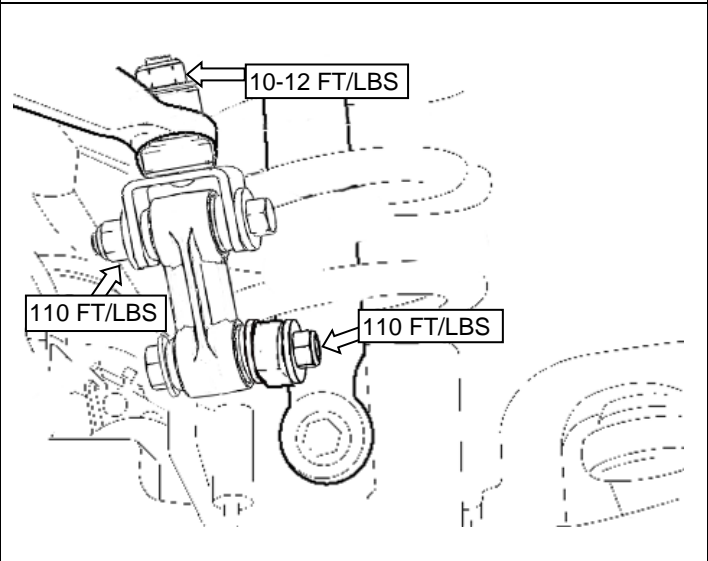

8. Tighten remaining bolts to 110 ft/lbs

Use a 22mm socket

9. Reinstall front wheels and torque to manufacturer recommendations.  
Road test vehicle and recheck connections.