

## INSTALL INSTRUCTIONS FOR 75-5140

### PART#: 75-5140 / 75-5140D

#### Vehicle Application

YEAR: 2020

MAKE: Ford

MODEL: F-250/F-350

ENGINE: 6.7L Powerstroke

**Note:** Kit may not fit with the following Aftermarket Parts installed:

- Body Lift or Lowering Kit
- Custom Hood
- Throttle Body Spacer / Upgrade

#### Tools Required

- 7mm, 8mm, 10mm, 13mm Socket and Wrench
- 10" Socket Extension or 4" 6" Socket Extensions
- 13mm Open/Box Combination Wrench
- 5/16" Nut Driver
- T20 Torx Bit/Driver
- Torque Wrench, 1/4" Drive
- Panel Popper
- Phillips Screwdriver
- Wire Cutters

**Note:** Approximate Install Time: 1 Hr 00 Mins for Kit Installation, 2 Hr 00 Mins for Battery Disconnect

#### S&B Filter Maintenance

**KF-1050 Cotton Cleanable :** If the enclosed filter is RED, it came pre-oiled from the factory. Click here for exact oil amount required for cleaning.

**KF-1050D Dry Extendable :** If the enclosed filters is WHITE, it is a disposable filter and should be discarded once it reaches capacity. This filter does not require oil, do not wash or oil this filter.

**Foam Filter:** Service and check the condition of your Foam Filter (J) every time you service your air filter. Wash it with water or gently blow it off with compressed air. If it can't be cleaned with water or compressed air, or it is torn or damaged, please replace the foam filter.

HP1473-00 is the replacement foam kit that includes (1) Foam Filter, (1) Foam Retainer, and (3) Screws.

#### Periodically Check the Following

- Intake Tube (T) and Filter (AB) connections and Intake Box (A) fasteners making sure they are tight.
- All electrical connections and wire harnesses moved during the installation of the intake and make

#### Before You Start

- Please read the entire product guide before proceeding.
- Ensure all parts are present.
- If you are missing any of the components, call our customer support at (909) 947-0015.
- Do not work on your vehicle while the engine is hot.

#### Performance Testing

After your installation is complete, engage the parking brake and start your engine. Listen for abnormal noises. If an air leak is detected, re-inspect hoses and connections as they may need to be repositioned and tightened.

sure they are secure and away from any hot or moving components.

- Check for any signs of abrasion or wear and tear on the intake tube, box, filter, and electrical harnesses moved or near the intake and repair/replace as necessary.

- Make sure the engine is turned off and the vehicle is in Park or the Parking Brake is set.

S&B FILTERS recommends that you keep your OE intake system in the event it is required in the future.

In order to maintain your warranty, all connections and components must be checked periodically for alignment and for proper tension on all connections. Failure to do so may void your warranty.

Use only S&B FILTERS cleaning and oil products to service your filter. Using any other brand oil and or cleaners on your S&B air filter may void your warranty

## **Air Box Plug Testing**

Stock air boxes are a significant contributor to poor airflow which is why S&B designs custom air boxes with secondary and/or enlarged openings. With that said, S&B recognizes the benefits of cooler air, so we have included a plug to seal off the opening if so desired. For optimal performance, we recommend that the intake be used without the plug except in conditions of extreme heat.

## **Operation in Rain or Snow**

If you are driving in heavy snowfall or extreme rain conditions, you should always check for accumulated snow and water on the air filter. The following is recommended after operating the vehicle up to 100 miles in heavy snowfall or extreme rain: At the earliest opportunity, open the hood and check the airbox and filter. If any snow has accumulated, make sure to remove the snow from the filter, box, and inlet. It is ok if the filter is a little wet. Wet filters will normally dry out on their own. If the filter is dripping wet, it should be replaced with another filter that is not wet. Do not reuse the dripping wet filter until it has naturally dried.

## **Warning!**

If your vehicle has a Vehicle Emission Control Information decal affixed to the factory airbox, a new replacement label must be obtained and installed in a readily visible position in the engine compartment in order to remain CARB compliant. Failure to do so will prevent the vehicle from passing a smog check. Replacement labels can be ordered from your local dealership. Regulations state that the VECI label shall not be affixed to any equipment which is easily detached from the vehicle. Label placement, under the hood on a painted surface, is recommended

## **CARB Status-Pending**

### **Emission Standard**

The California Air Resource Board (CARB) requires that an E.O. Identification label be applied to the vehicle in order to pass a smog check inspection when a Performance Intake Kit has been installed. You must place the E.O. Label provided on or near the intake kit after installation so that a smog check technician can easily verify the E.O. Number. Check the status of the exemption process by looking up a specific part number at [www.sbfilters.com](http://www.sbfilters.com). The CARB Exemption number and/or status is listed under the Product Details section for each part number. If the status shows as "Pending," CARB has yet to issue an exemption but the product has been submitted. Products that have not been issued an E.O. number are street legal in most states, but may not be used on emission controlled vehicles in the state of California and are for off-road use only. If you purchased your kit from S&B Filters directly, we will automatically mail you your Exemption Sticker when it is issued to us. If you purchased your kit from an authorized S&B Filters Dealer, log onto our web site and register to receive your Exemption Sticker.

# EXPLODED VIEW

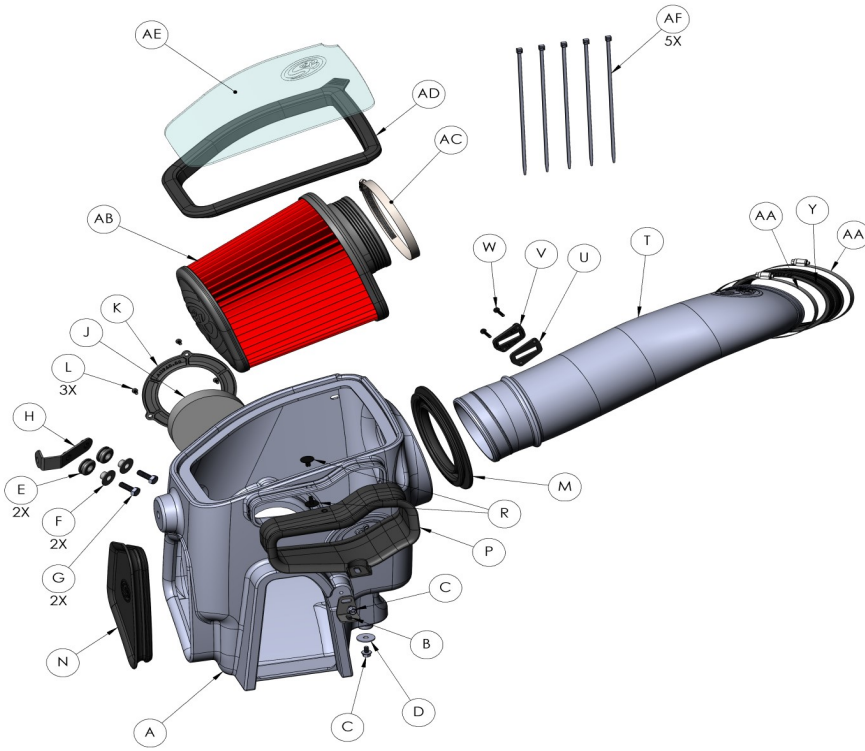

ITEM NO.	QTY.	PART NUMBER	DESCRIPTION
A	1	AL1370B-00	Air Box
B	1	AI2477-00	Bracket, Front Scoop
C	2	AI2452-00	Hex Flange Bolt, M6 x 10 mm Long, Steel, Zn Pltd
D	1	AI2453-00	Washer, Flat, 1/4", 1.00" OD, Steel, Zn Pltd
E	2	AI1563-00	Grommet, 1/2" ID x 1-1/16" OD, 7/16" Thk, 3/16" Panel
F	2	AI2296-00	Bushing, Shoulder, Aluminum
G	2	AI1214-00	HHCS, M8-1.25 x 25mm Long, Class 8.8, Zn Pltd
H	1	AI2475-00	Bracket, Air Box
J	1	AI1961-00	Foam Filter
K	1	AI1960-00	Foam Retainer
L	3	AI1473-00	Pan Head Phil Mach Screw, M4 x 10mm long, SS
M	1	AI1650C-00	Box Seal
N	1	AI2464C-00	Air Box Plug
P	1	AI1956C-00	Air Box Inlet
R	2	AI1762-00	Plastic Rivet, Interlocking Shank, 1/4" dia
T	1	AL1370-00	Intake Tube
U	1	AI1823-00	Gasket, MAF Mount
V	1	AI1822-00	MAF Mount, Black
W	2	AI1837-00	Sems Screw, #8-32 x .75" Lg, SS
Y	1	AI1523C-00	Straight Coupler, 4.50" ID x 2.13" LG
AA	2	AG1009-00	Hose Clamp, #72
AB	1	KF-1050	Filter
AC	1	AG1010-00	Hose Clamp, #80
AD	1	AI2465C-00	Lid Seal
AE	1	AI2478-00	Lid
AF	5	AI1750-00	Cable Tie, 9" Long

# INSTALLATION STEPS

## STEP 1

With the ignition switched off and the parking brake set, disconnect the negative battery cables on both batteries and the positive battery cable on the passenger side.

**Note:** Failure to disconnect the battery for 2 hours may cause the CEL to illuminate upon completion of the installation and subsequent operation. DO NOT SKIP THIS STEP!

**Tools Required:** 10mm Socket/Wrench

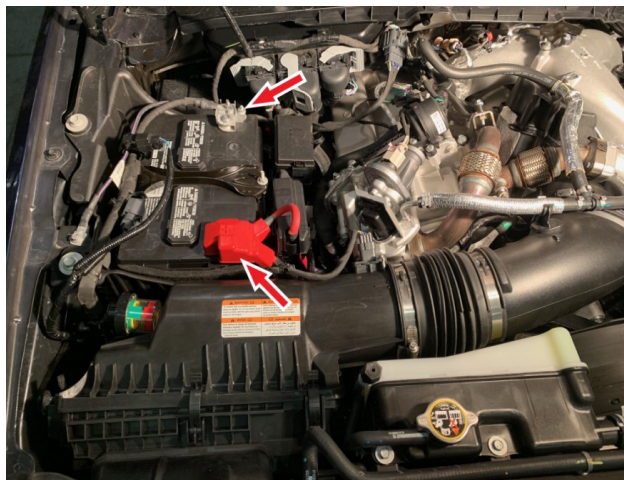

## STEP 1 (IMAGE 2)



## STEP 2

Disengage the white locking clip, press down on the tab, then pull out to disconnect the MAF sensor harness from the MAF sensor.



### STEP 3

Remove the ribbed push in clip on the wiring harness from the stock intake lid.

**Tools Required:** Panel Popper or Flat Blade Screwdriver



### STEP 4

Loosen the hose clamps on the intake tube connected to the turbo inlet and intake box.

**Tools Required:** 7mm Socket/Wrench or Flat Blade Screwdriver

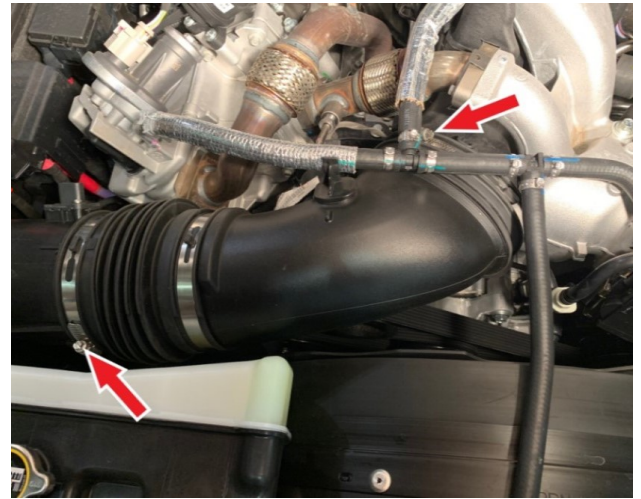

### STEP 5

Remove the coolant line from the intake tube clip then remove the intake tube from the vehicle.



### STEP 6

Unhook the three clips on the stock intake box lid. Remove the stock intake box lid from the vehicle.

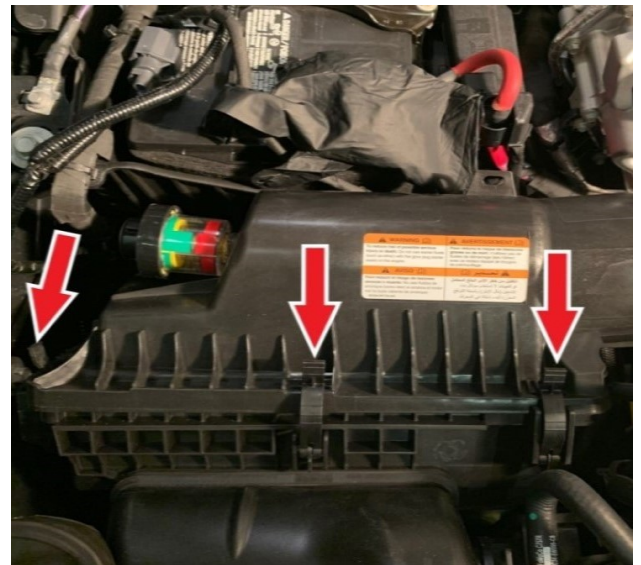

## STEP 7

Carefully remove the stock intake filter.



## STEP 8

Pop-out the stem and remove the push in rivet securing the stock front inlet. Set the push in rivet aside, it will be reused in Step 37.

**Tools Required:** Panel Popper or Flat Blade Screwdriver.

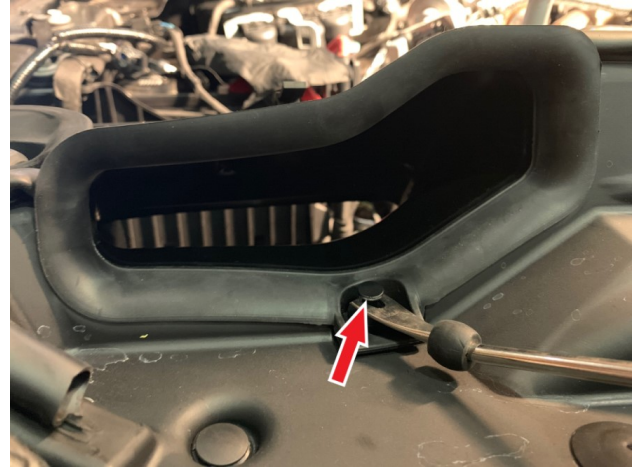

## STEP 9

Wiggle the stock front inlet loose and lift up to remove it from the vehicle.



## STEP 10

Using socket extension(s), remove the screw holding the stock intake box to the grill inlet duct. Set the screw aside to be reused in Step 27.

**Tools Required:** 10" Socket Extension or 4" + 6" Socket Extension, 8mm Socket/Wrench

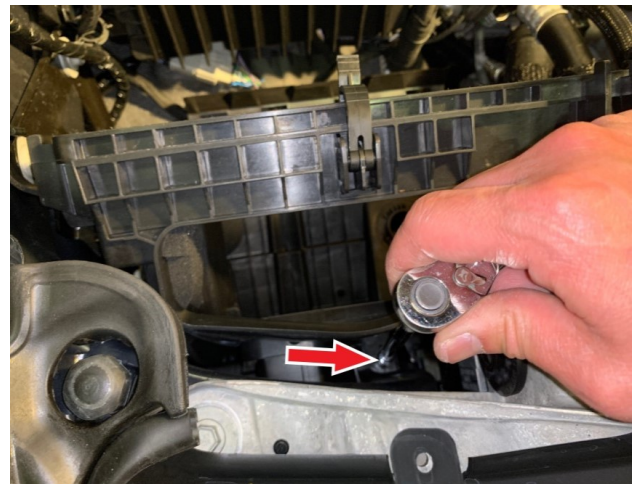

## STEP 11

Firmly but carefully rock and lift the intake box free from the lower grommet and free the side rubber bushings from the side saddle bracket. Remove the intake box from the vehicle.

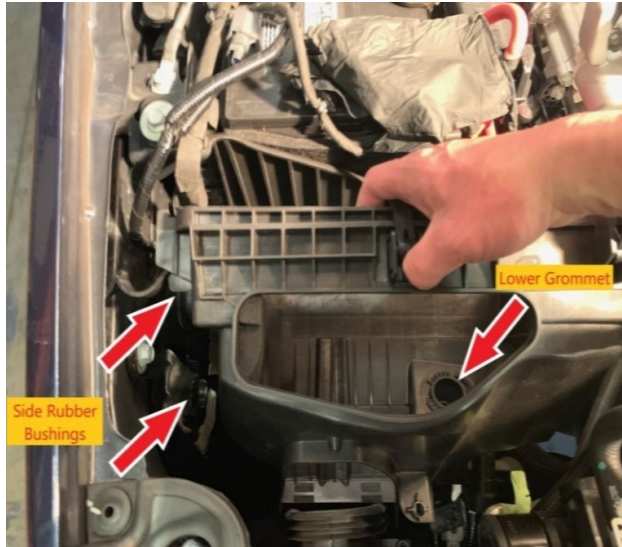

## STEP 12

Make sure the bottom box grommet stayed in the vehicle and did not get pulled out with the intake box.

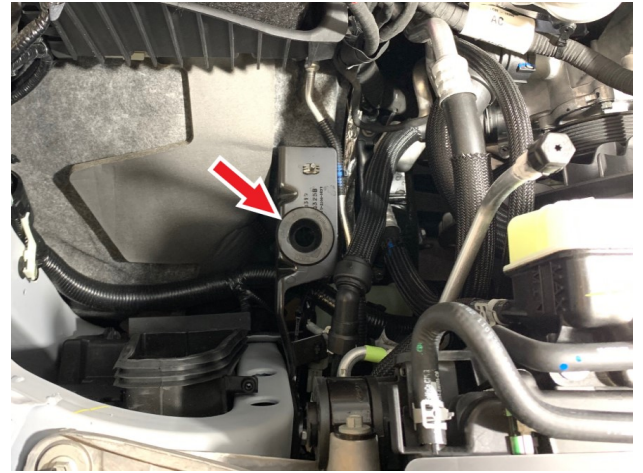

## STEP 13

Remove the two screws that hold the saddle bracket and remove the bracket from the vehicle. Set the screws aside, they will be reused in Step 21 and Step 25.

Tools Required: 13mm Socket/Wrench



## STEP 14

Install Front Scoop Bracket (B) to the Air Box (A) using Hex Flange Bolt (C). Slide the Front Scoop Bracket (B) towards the scoop opening and tighten Hex Flange Bolt (C).





## STEP 15

Install Washer (D) to the bottom of Air Box (A) using Hex Flange Bolt (C).

**Tools Required:** 10mm Socket/Wrench or Box/Open Wrench

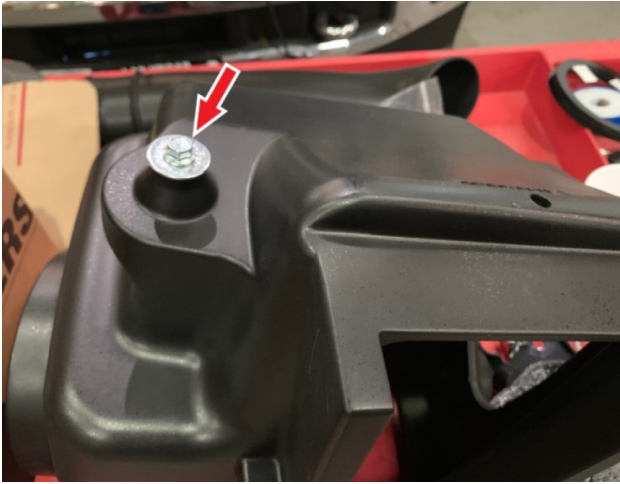

## STEP 16

Install Foam Filter (J) and Foam Retainer (K) to the Air Box (A) using M4 Screws (L).

**Tools Required:** Phillips Screwdriver



## STEP 17

Install Grommets (E) to the Air Box (A). Make sure that Air Box (A) is fully seated into the groove of both Grommets (E) and that both sides of the Grommets (E) are flat against the wall of the Air Box (A).



## STEP 17 (IMAGE 2)



## STEP 18

From the inside of the Air Box (A), install Shoulder Bushings (F) into the Grommets (E)



## STEP 19

Install Box Seal (M) to the Air Box (A). Make sure that the Air Box (A) is fully seated into the groove of Box Seal (M).



## STEP 20

Determine if you want to install the Air Box Plug (N) to the Air Box (A). See the "Air Box Plug Testing" section at the beginning of the Install Instructions to decide the desired setup. If the Air Box Plug is desired, simply press the Box Plug into the Box opening until it snaps fully into place.



## STEP 21

Install the Air Box Bracket (H) onto the fender frame using the threaded hole (closest to the battery) of the saddle bracket removed in Step 13. Reuse one saddle bracket screw removed in Step 13 and hand tighten only.

Tools Required: 13mm Box/Open Wrench.



## STEP 22

Carefully work the Air Box (A) into the vehicle. The space is tight but carefully move/rotate the box to make space for the grill inlet duct, fender, and coolant reservoir as you lower the Air Box. Once the Air Box is below the fender it will become easy to position the Air Box properly then push down to fully seat the Washer (D) into the stock bottom box grommet shown in Step 12. The AirBox should snap into the grommet.

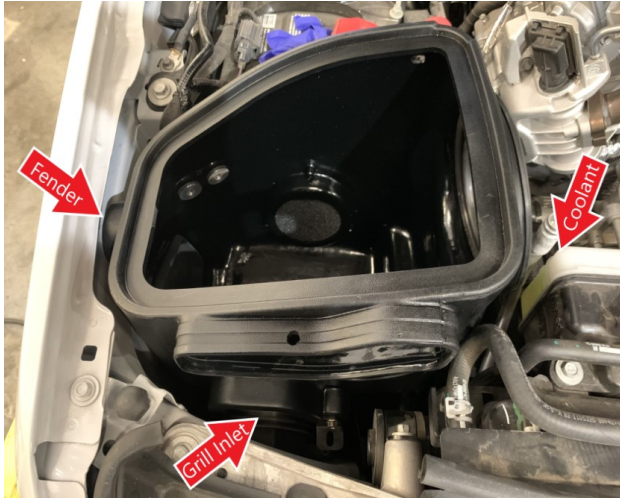

## STEP 24

After the holes in Step 23 are in line and matched, make sure that the Front Scoop Bracket (B) slotted hole is over the threaded hole of the stock grill inlet duct. If the Front Scoop Bracket (B) needs to be repositioned, remove the Air Box (A) from the vehicle and readjust the Front Scoop Bracket (B).

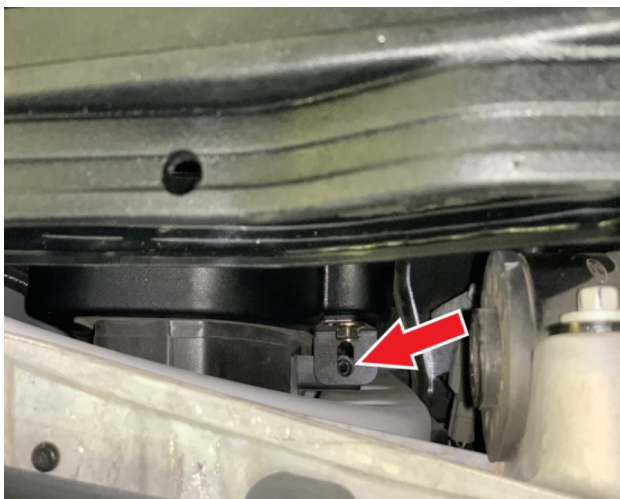

## STEP 23

Position the Air Box so that the hole in Air Box (A) is in line and matched with the threaded hole in the fender frame and the holes in the Shoulder Bushings (F) are also in line and matched with the threaded holes in Air Box Bracket (H). Rotate the Air Box Bracket (H) as required.

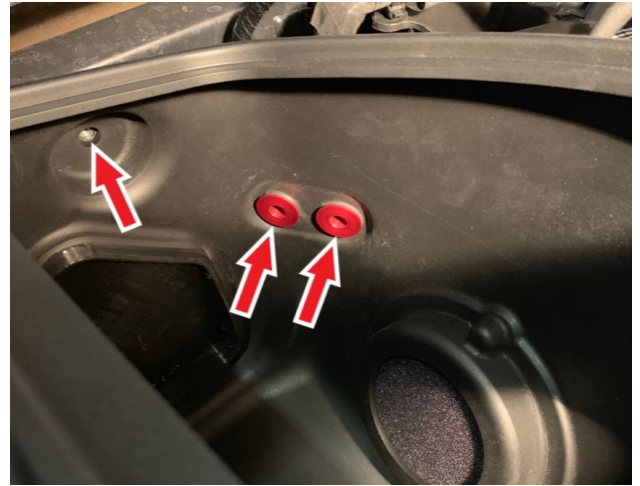

## STEP 25

After the holes in both Step 23 and Step 24 are aligned, reuse the OE saddle bracket screw removed in Step 13 to fasten the Air Box (A) to the fender frame. Use the M8 Screws (G) to fasten the Shoulder Bushings (F) to the Air Box Bracket (H). Tighten all fasteners.

**Tools Required:** 13mm Socket/Wrench

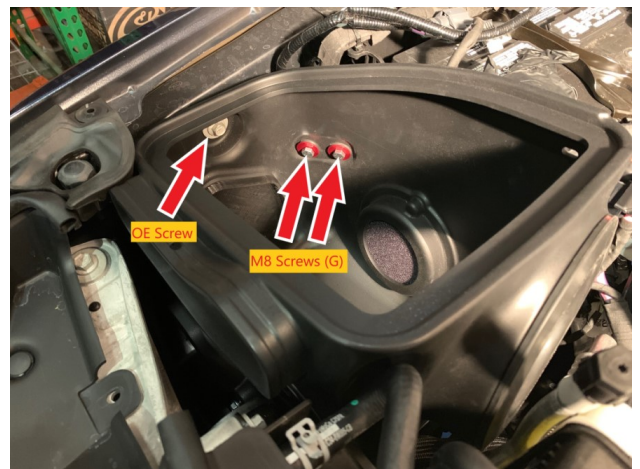

## STEP 26

Tighten the screw that was hand tightened in Step 21 to secure the Air Box Bracket (H) to the fender frame.

**Tools Required:** 13mm Box/Open Wrench



## STEP 27

Reuse the screw removed in Step 10 to fasten the stock grill inlet duct to the Front Scoop Bracket (B). Use tape to hold the screw to the socket if you have trouble guiding the screw into the stock grill inlet. Be careful not to over tighten since the threaded hole in the grill inlet duct is plastic.

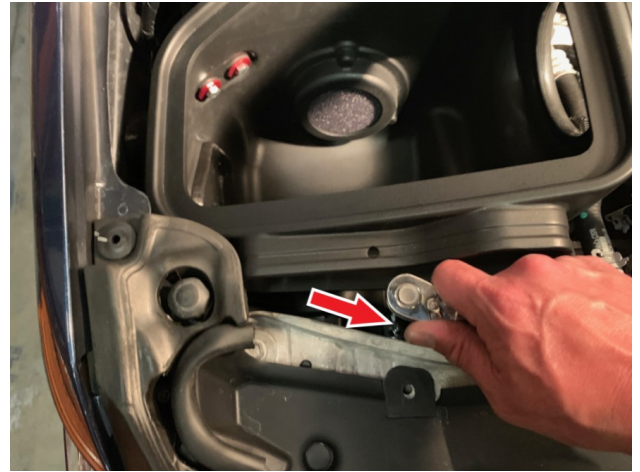

## STEP 28

Carefully bend the AC service port line slightly so that the center of the cap lines up with the seam of the coolant reservoir to give clearance for the Intake Tube (T).

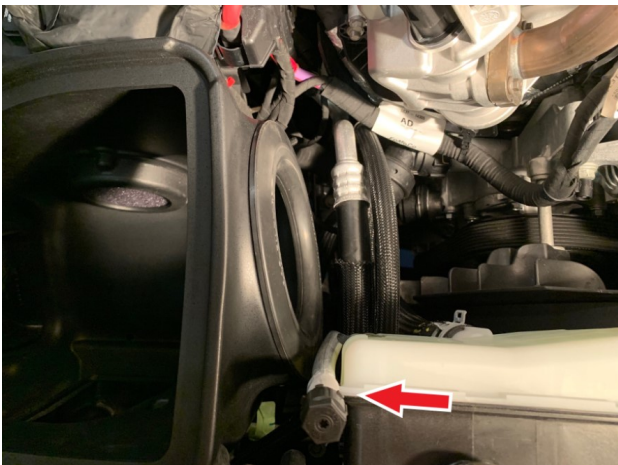

## STEP 29

Remove the two screws holding the stock MAF sensor to the stock intake box lid and remove the stock MAF sensor.

**Tools Required:** T20 Torx Bit/Driver



### STEP 30

Make sure the stock gasket is on the MAF sensor and place the MAF Mount (V) first and then the MAF Mount Gasket (U) second on to the stock MAF sensor as shown.



### STEP 30 (IMAGE 2)

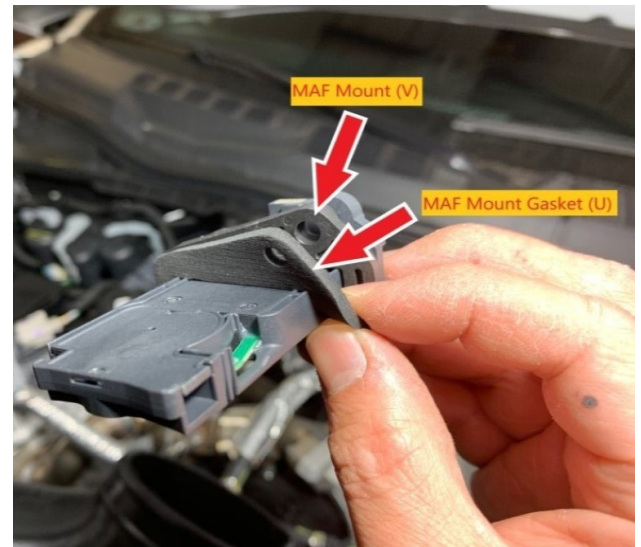

### STEP 31

Mount the MAF sensor assembly to the Intake Tube (T) using two #8-32 Screws (W). Make sure that the arrow on the MAF sensor is pointing towards the oval end of the Tube (T).

Tools Required: Phillips Screwdriver



### STEP 32

Slide the Coupler (Y) over the Intake Tube (T) with the two #72 Hose Clamps (AA) up to the edge of the oval end of the Intake Tube as shown. Leave the Hose Clamps loose.

Tools Required: 5/16" Nut Driver



### STEP 33

Insert the Intake Tube (T) into the Box Seal (M) located on the Air Box (A). Work the Intake Tube (T) slowly, at the angle shown, until the bead on the Tube is up against the Box Seal (M).

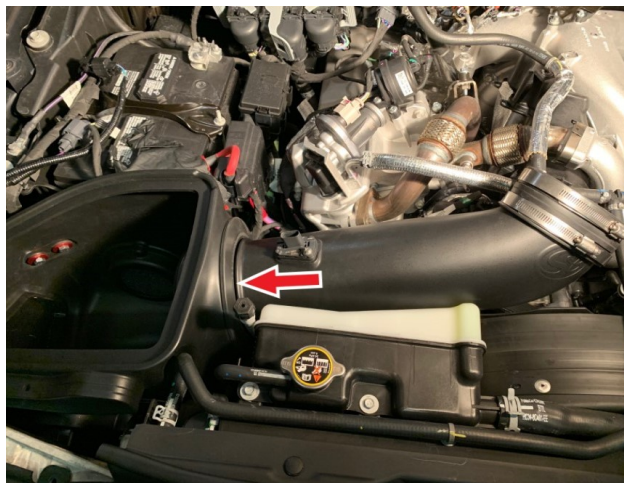

### STEP 34

Rotate the Intake Tube (T) until it is aligned with the turbo inlet and then slide the Coupler (Y) over the turbo inlet. Fully seat the Coupler (Y) until it is up against the flange of the turbo inlet all around. The bead on the Intake Tube (T) should also be by the edge of the Coupler (Y) all around.

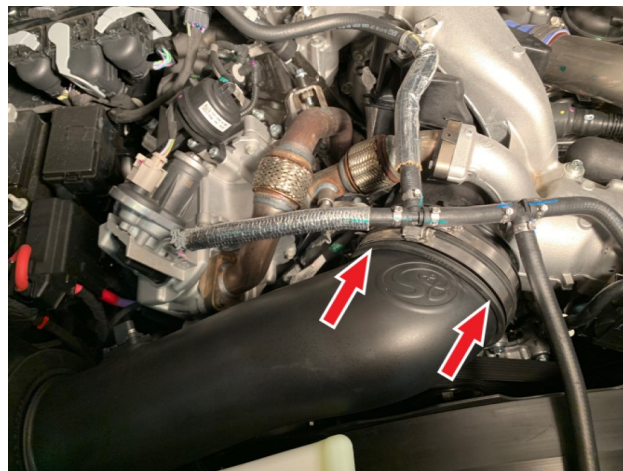

### STEP 35

The coolant hoses will be sitting on top of the Coupler (Y) so position the Hose Clamp screws away from the hoses as shown, then tighten both #72 Hose Clamps (AA).

Tools Required: 5/16" Nut Driver.

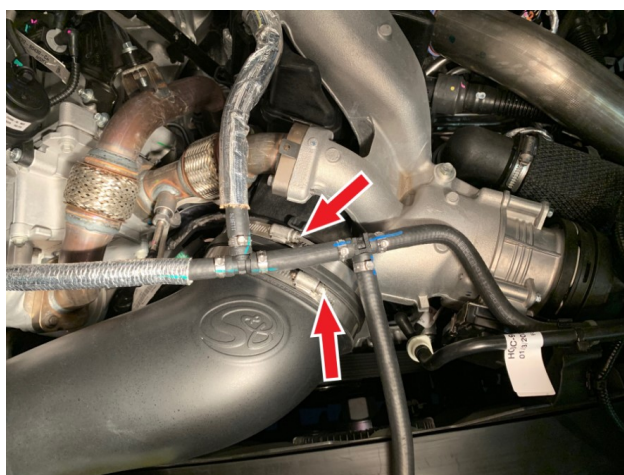

### STEP 36

Attach the Air Box Inlet (P) onto the Air Box (A) with the Plastic Rivets (R). Squeeze the Plastic Rivets (R) together so they lock into place.



### STEP 37

Secure the Air Box Inlet (P) onto the vehicle with the push in rivet removed in Step 8. Make sure the push in rivet is fully inserted and the center stem pushed all the way down.



### STEP 38

Insert the Filter (AB) with #80 Hose Clamp (AC) into the Air Box (A) with the Filter flange pointing up.



### STEP 39

Install the Filter (AB) and #80 Hose Clamp (AC) onto the Intake Tube (T). Insert the Intake Tube (T) fully into the Filter (AB) until it stops on the Filter flange shoulder. The base of the Filter flange should line up with the bead on the Tube. Rotate the Filter until the straight section of the filter becomes vertical as shown. Tighten the Hose Clamp (AC).

**Tools Required:** 5/16" Nut Driver.

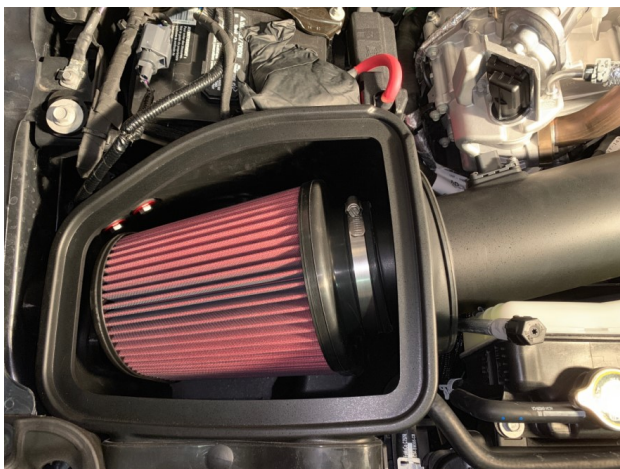

### STEP 39 (IMAGE 2)

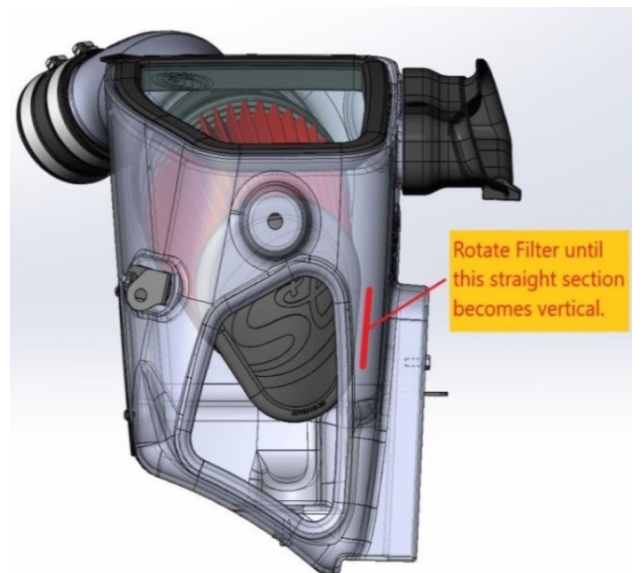

## STEP 40

Peel off the protective covering on the clear Lid (AE). Don't forget to remove the protective covering around the S&B logo.



## STEP 41

Install the Lid Seal (AD) around the outside edge of the clear Lid (AE).



## STEP 42

Install the clear Lid (AE) with Lid Seal (AD) onto the Air Box (A). Start by inserting the Lid Seal groove over the Air Box opening on one corner first and then work your way around the Air Box. Make sure that the Lid Seal groove snaps over the entire Air Box opening. Check all around the Lid Seal snap groove to make sure it has snapped over the entire Air Box opening.

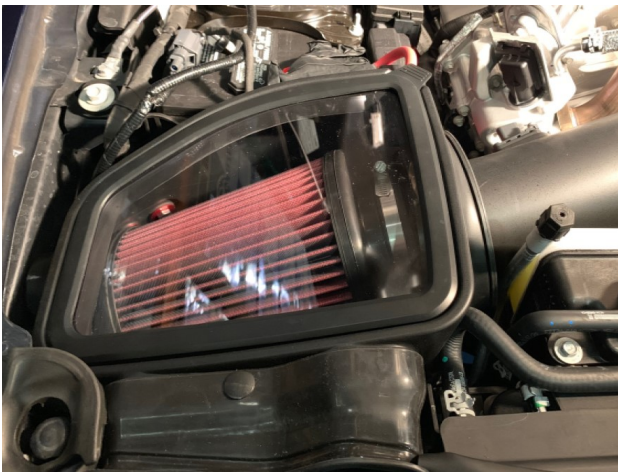

## STEP 43

Reconnect the MAF sensor harness to the MAF sensor. Make sure to engage the white locking clip. Then insert the ribbed push in harness clip into the slotted hole located in Air Box (A).

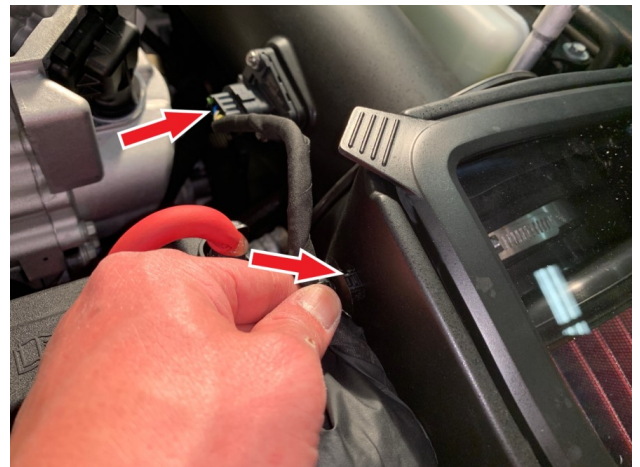



## STEP 44

After the batteries have been disconnected for at least 2 hours, reconnect the positive battery terminal on the passenger side first and torque the terminal clamp nut to factory specifications, 80 lb-in (9 Nm), and place the cover over the terminal. Then reconnect the negative terminals on both batteries and torque the terminal clamp nut to factory specifications, 80 lb-in (9 Nm).

**Tools Required:** 10mm Socket/Torque Wrench

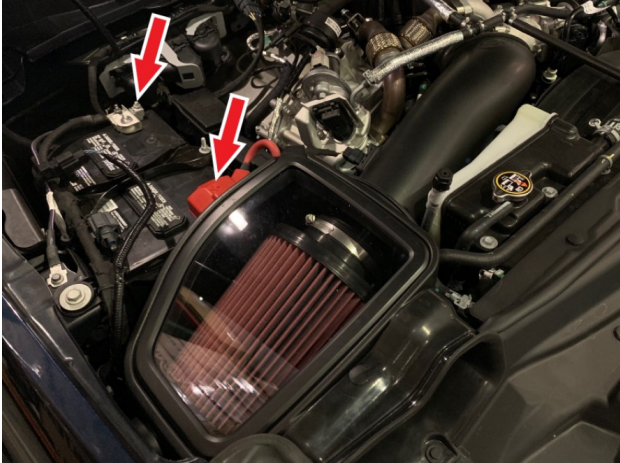

## STEP 45

Look for any loose wires/harness that may be close or touching the Intake Box (A) or Air Box Bracket (H) and secure them away with Cable Ties (AF) to prevent them from wearing during vehicle movement and vibration.



## STEP 44 (IMAGE 2)



## STEP 46

Inspect your installation, make sure the kit is properly positioned and all fasteners and hose clamps are secured. Keep all stock parts in case you would ever need to reinstall the stock intake assembly. Affix the ID label near the Intake kit. If you are an installer, give the owner the QR code for the Installation Instructions so that he/she is aware of the Maintenance and Operation procedures given at the beginning of the Instructions. The installation is now complete.

