



**DOWNLOAD THE LATEST  
INSTALL MANUALS AT  
[www.bddiesel.com](http://www.bddiesel.com)**



## 2011-2018 FORD 6.7L POWERSTROKE Installation Instructions

1050470	2011-2018 FORD SUPERDUTY
1050471	2011-2018 FORD SUPERDUTY W/O CP3
1050470-SB	2011 & 2012-'18 PULLEY CONVERSION KIT (ALL 2011 OR 2012+ DUAL ALTERNATOR)

**PLEASE READ ALL INSTRUCTIONS BEFORE INSTALLATION**

BD ENGINE BRAKE, INC.

Plant Address: A10-33733 King Rd, Abbotsford, BC, Canada V2S 7M9

US Shipping Address: 88-446 Harrison St, Sumas, WA 98295 US Mailing Address: PO Box 231, Sumas, WA 98295









Phone: 604-853-6096 Fax: 604-853-8749 Internet: [www.bd-power.com](http://www.bd-power.com)

# **KIT CONTENTS:**

Please check to make sure that you have all the parts listed in this kit **before** you start the disassembly of your truck.

1050470 – Kit Contents		
<b>1500731</b>	<b>1500708</b>	
		
<b>Qty: 1</b>		
<b>0445020037</b>	<b>1500716</b>	<b>1500719</b>
		
<i>Duramax CP3 Pump</i> <small>(Not included on 1050471)</small>	<i>HP Fuel Line</i>	<i>Quick Connect Adapter</i>
<b>Qty: 1</b>	<b>Qty: 1</b>	<b>Qty: 2</b>
<b>1500721</b>	<b>1500720</b>	<b>GATK081298</b>
		
<i>Quick Connect Fitting</i>	<i>Quick Connect Retainer</i>	<i>Serpentine Belt</i>
<b>Qty: 2</b>	<b>Qty: 2</b>	<b>Qty: 1</b>

<b>1050470 – Kit Contents Cont.</b>		
<b>DAY89094</b>	<b>1500725</b>	<b>1500715</b>
		
<i>Idler Pulley</i>	<i>Shroud Bracket</i>	<i>Bracket Standoff</i>
<b>Qty: 1</b>	<b>Qty: 1</b>	<b>Qty: 1</b>
<b>1502040</b>	<b>1500723</b>	<b>1500727</b>
		
<i>HiFlow CP3 Feed Fitting</i>	<i>Quick Connect Straight Fitting</i>	<i>Quick Connect 90Deg Fitting</i>
<b>Qty: 1</b>	<b>Qty: 1</b>	<b>Qty: 3</b>
<b>1500704</b>	<b>F00N200499</b>	<b>1500728</b>
		
<i>Fuel Rail Fitting</i>	<i>CP3 Output Fitting</i>	<i>CP3 Return Banjo Fitting</i>
<b>Qty: 1</b>	<b>Qty: 1</b>	<b>Qty: 1</b>

<i>1050470 – Kit Contents Cont.</i>		
<b>1500718</b>	<b>FT-0424777</b>	<b>FT-99604842</b>
		
<i>CP3 Plug</i>	<i>O-Ring -8 ORB</i>	<i>O-Ring</i>
<b>Qty: 1</b>	<b>Qty: 2</b>	<b>Qty: 4</b>
<b>GEN-19639</b>	<b>1604054</b>	<b>1453934</b>
		
<i>Push Pin</i>	<i>1/2" Fuel Hose</i>	<i>M8 x 45 Bolt</i>
<b>Qty: 2</b>	<b>Qty: 7ft</b>	<b>Qty: 3</b>
<b>1601711</b>	<b>W701629-S437</b>	<b>1401556</b>
		
<i>M8 x 25 Socket Head Bolt</i>	<i>Ford Bolt</i>	<i>M8 Washer</i>
<b>Qty: 1</b>	<b>Qty: 1</b>	<b>Qty: 6</b>

<b>1050470 – Kit Contents Cont.</b>		
<b>1402609</b>	<b>FT-40388</b>	<b>FT-1190681</b>
		
<i>M8 x 24 Washer</i>	<i>M18 Split Washer</i>	<i>M8 Lock Nut</i>
<b>Qty: 1</b>	<b>Qty: 1</b>	<b>Qty: 3</b>
<b>FT-MJ2740000ZP00</b>	<b>FT-11115722</b>	<b>1502015</b>
		
<i>M18 Jam Nut</i>	<i>M8 x 16 Bolt</i>	<i>Banjo Bolt</i>
<b>Qty: 1</b>	<b>Qty: 1</b>	<b>Qty: 1</b>
<b>1502019</b>		<b>1452821</b>
		
<i>Seal Washer</i>		<i>Gear Clamp</i>
<b>Qty: 2</b>		<b>Qty: 1</b>

<i>1050470 – Kit Contents Cont.</i>		
<b>1500387</b>	<b>FT-0606434</b>	<b>1500722</b>
		
<i>Spring Clamp</i>	<i>Loctite Threadlock</i>	<i>CP3/CP4 Harness</i>
<b>Qty: 2</b>	<b>Qty: 1</b>	<b>Qty: 1</b>

<i>**1050470-SB – Optional Kit Contents**</i>	
<b>CC3Z-8553-C</b>	<b>GAT36234</b>
	
<i>Smooth Fan Pulley</i>	<i>Smooth Idler Pulley</i>
<b>Qty: 1</b>	<b>Qty: 2</b>

# Contents

1050470 – Kit Contents .....2

1050470 – Kit Contents Cont.....3

1050470 – Kit Contents Cont.....4

1050470 – Kit Contents Cont.....5

1050470 – Kit Contents Cont.....6

\*\*1050470-SB – Optional Kit Contents\*\* .....6

SPECIAL REQUIRED TOOLS.....7

OPTIONAL ACCESSORIES.....7

INTRODUCTION .....8

KIT FIT NOTES .....8

PRE-INSTALLATION.....8

REMOVAL.....9

INSTALLATION .....14

OPERATION INSTRUCTIONS.....31

SPECIAL NOTES .....31

## **SPECIAL REQUIRED TOOLS**

- 10mm 12point (Triple Square) bit
- Cooling Fan clutch removal tools (FORD wrenches 205-036 and 303-214)
- 19mm Crows foot wrench

## **OPTIONAL ACCESSORIES**

**1050470-SB** - Single Sided Belt conversion for 2011 model year trucks, *and* trucks originally equipped with dual alternators.

## INTRODUCTION

When trying to increase power levels of diesel engines, the high pressure fuel pump originally installed in the vehicle is found to be insufficient. Upgraded turbochargers can supply the engine with more air than the high pressure fuel pump can supply for. The BD Venom Dual Fuel Kit allows 6.7L Powerstroke owners to increase the high pressure fueling capabilities of their engine, by adding a second high pressure fuel pump. This kit mounts a Bosch CP3 to the engine, and increases the power potential of upgraded turbochargers and other engine modifications.

## KIT FIT NOTES



**This kit requires the use of custom tuning for the operation of the additional high-pressure fuel pump.**

**If factory intake manifold assembly is still in use, some modification to cold air intake may be required for pump pulley clearance.**

**2011 model year *and* all year dual alternator trucks will require optional 1050470-SB kit for conversion from double sided serpentine belt to single sided belt.**

**If equipped with dual alternators, aux alternator will need to be removed, and a single-alternator water pump may be required. Kit will not work with factory dual alternators.**

## PRE-INSTALLATION

Secure vehicle and chock wheels to prevent vehicle from rolling. Record radio settings then disconnect the negative terminals on both of the vehicle's batteries, and then disconnect the positive terminals.

For additional technical information, refer to Ford Technical Information or other shop repair manuals (Mitchell, Alldata, etc...)

BD ENGINE BRAKE, INC.

Plant Address: A10-33733 King Rd, Abbotsford, BC, Canada V2S 7M9

US Shipping Address: 88-446 Harrison St, Sumas, WA 98295 US Mailing Address: PO Box 231, Sumas, WA 98295

Phone: 604-853-6096 Fax: 604-853-8749 Internet: [www.bd-power.com](http://www.bd-power.com)



**REMOVAL**

**VEHICLE SHOULD BE SAFELY SECURED BEFORE INSTALLATION.**

1. Remove intake tube assembly, and associated parts. (Also referred to as the air cleaner outlet pipe).

**Note:** Refer to shop manual for additional removal details if required.

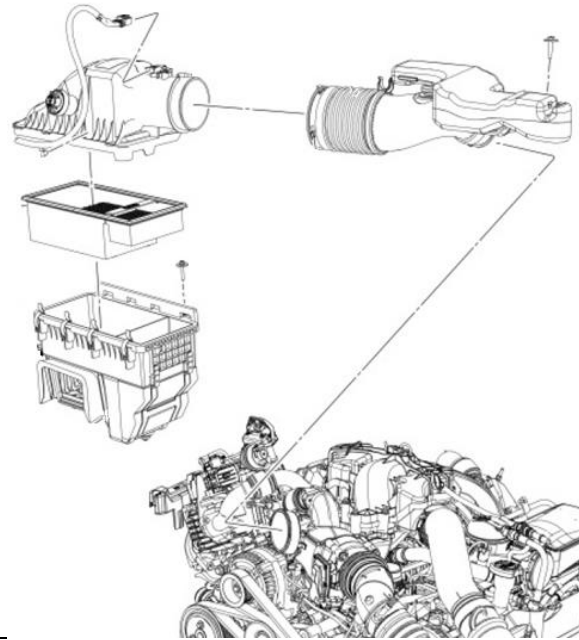

2. Using a 13mm socket, remove fan stator nuts and pull stator away from engine, to allow access to the cooling fan clutch.

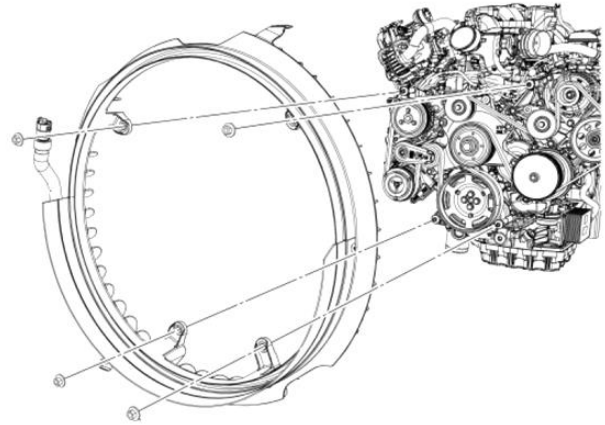

3. Unplug cooling fan connector, and unbolt bracket from engine using a 13mm socket.

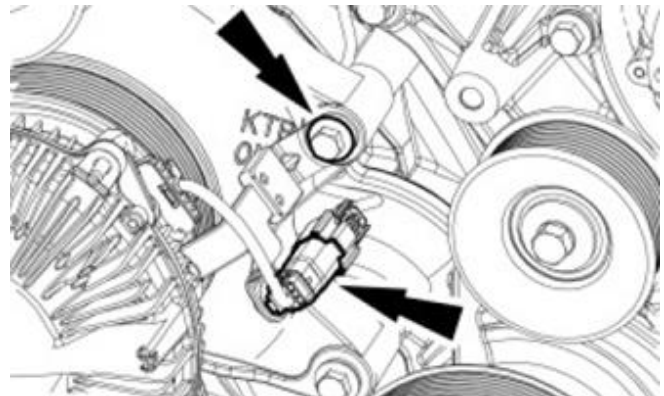

BD ENGINE BRAKE, INC.

Plant Address: A10-33733 King Rd, Abbotsford, BC, Canada V2S 7M9

US Shipping Address: 88-446 Harrison St, Sumas, WA 98295 US Mailing Address: PO Box 231, Sumas, WA 98295

Phone: 604-853-6096 Fax: 604-853-8749 Internet: [www.bd-power.com](http://www.bd-power.com)

4. Remove cooling fan from pulley hub. Carefully lay fan against radiator inside fan shroud housing.

**Note:** Removal may require the use of special fan clutch removal wrenches.

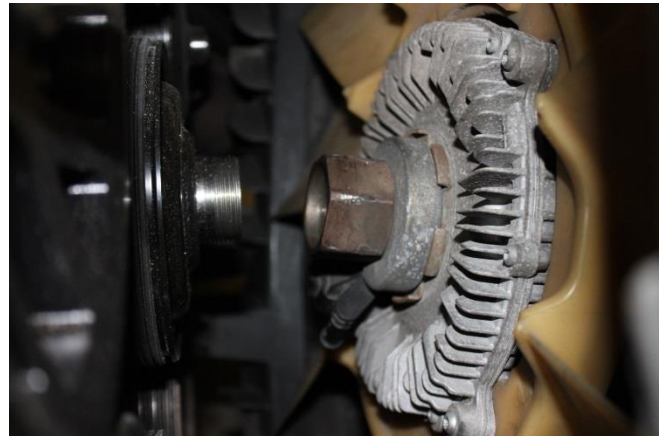

5. Using a 3/8in drive ratchet or breaker bar, remove factory serpentine belt by rotating tensioner clockwise and pulling belt off.

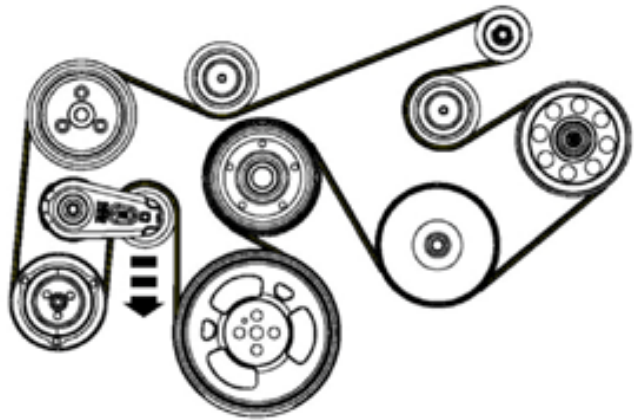

6. Cut plastic ties, and using a 10mm socket, remove plastic wiring loom(s) located over the passenger side valve cover.

**Note:** This wiring will be tucked behind installed CP3 pump.

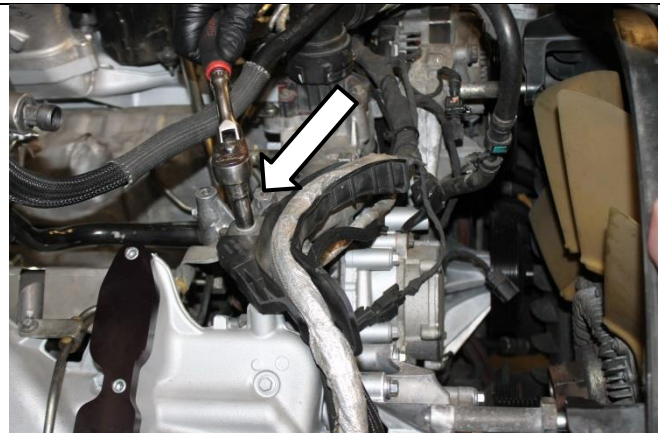

7. Un-plug OEM CP4 pump, and pull wiring out toward front of engine for access to connector.



8. Remove the grey plastic insert from the OEM CP4 connector using a small screw driver. This part will be modified to fit the new CP3 to CP4 wiring harness.



9. Using a small file, remove the keyways (ribs) on both sides of the grey plastic insert. Then install back into OEM CP4 connector.

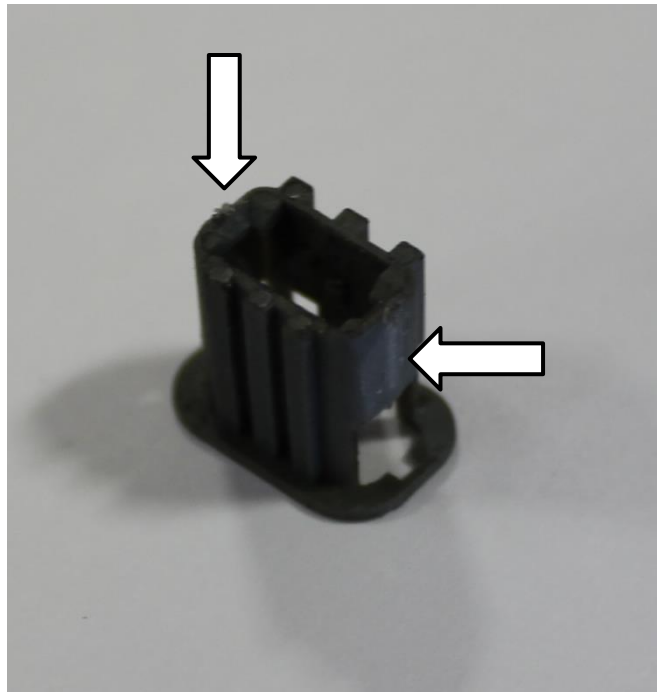

BD ENGINE BRAKE, INC.

Plant Address: A10-33733 King Rd, Abbotsford, BC, Canada V2S 7M9

US Shipping Address: 88-446 Harrison St, Sumas, WA 98295 US Mailing Address: PO Box 231, Sumas, WA 98295

Phone: 604-853-6096 Fax: 604-853-8749 Internet: [www.bd-power.com](http://www.bd-power.com)

10. Remove passenger side fan shroud support stud, using a 30mm wrench.

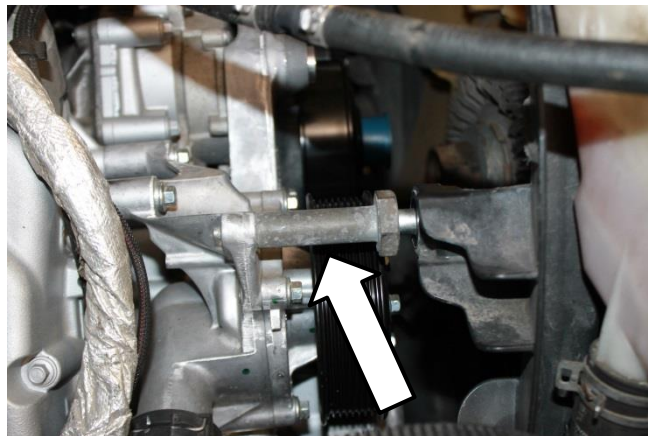

11. Remove upper bolt from secondary water pump, using 10mm socket.

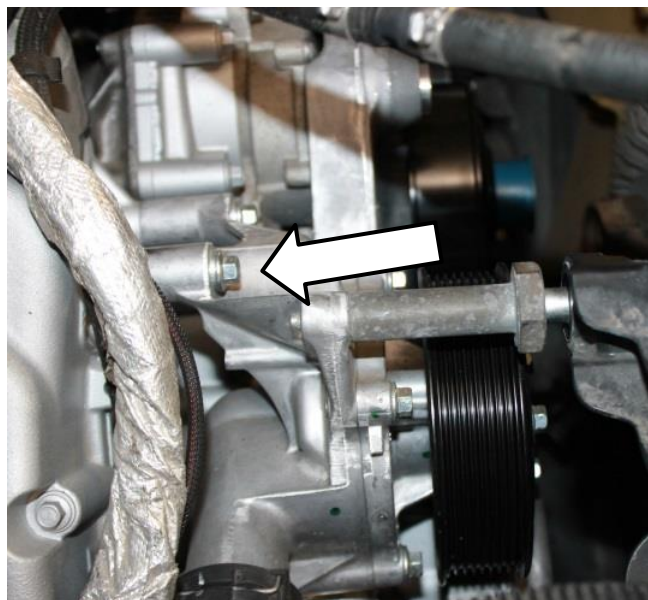

12. Remove both idler pulleys using a 15mm socket. These will be relocated to CP3 bracket, once installed.

**Note:** If these pulleys are grooved, they will be replaced with smooth pulleys from the optional kit 1050475-SB, using OEM hardware.

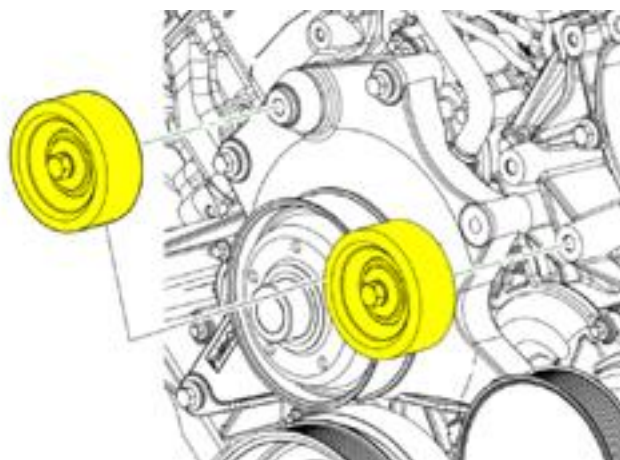

13. **Note:** If originally equipped with a single sided serpentine belt, skip to step 16 of removal process.

If the truck was outfitted with a double sided belt, and a grooved fan drive pulley as shown to the right, move onto the following removal process steps to install optional smooth fan pulley hub.



14. Using 13mm socket, remove fan pulley hub from front of engine.

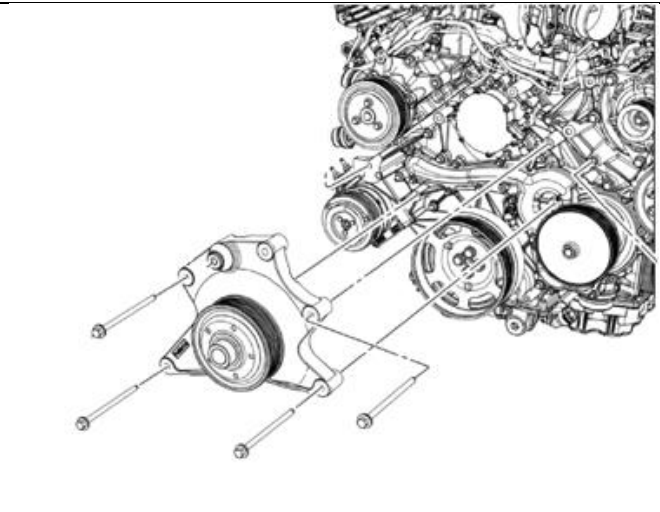

15. Using 13mm Socket, install smooth fan pulley hub CC3Z-8553-C, found in optional kit 1050470-SB. Torque fasteners to 18 ft-lbs. Leave upper three (3) bolts loose for installation of CP3 bracket assembly.

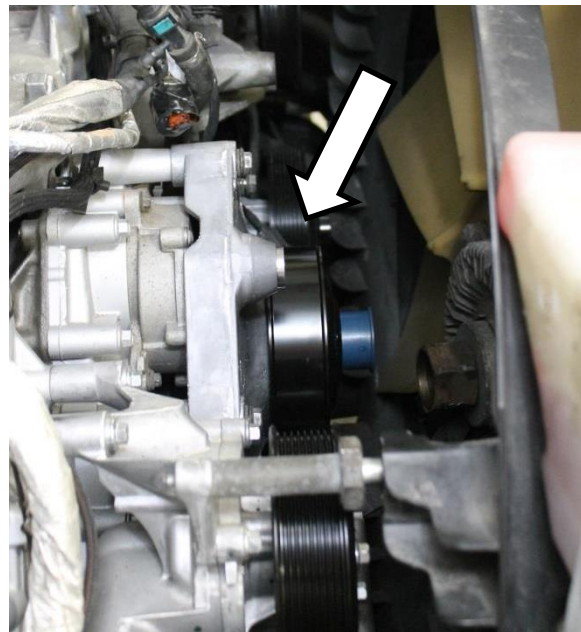

BD ENGINE BRAKE, INC.

Plant Address: A10-33733 King Rd, Abbotsford, BC, Canada V2S 7M9

US Shipping Address: 88-446 Harrison St, Sumas, WA 98295 US Mailing Address: PO Box 231, Sumas, WA 98295

Phone: 604-853-6096 Fax: 604-853-8749 Internet: [www.bd-power.com](http://www.bd-power.com)

16. Using 13mm socket, remove three (3) upper bolts from fan pulley hub to allow the CP3 bracket to be installed.

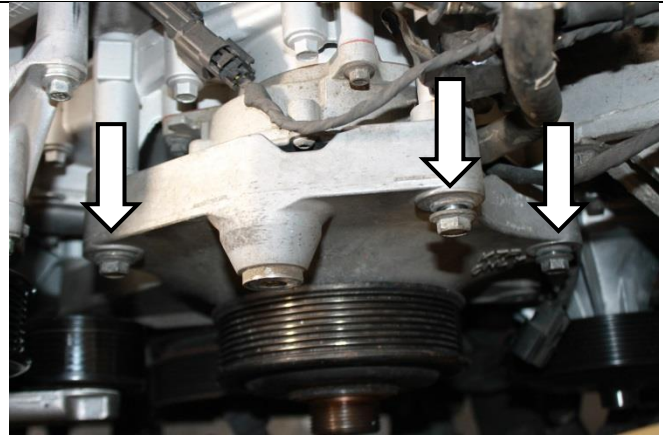

## INSTALLATION

17. This kit was designed for use with a LBZ/LMM style cp3 pump.

**Note:** Fuel injection equipment is manufactured to very precise tolerances and fine clearances. To prevent fuel system damage, it is essential that absolute cleanliness is observed when working with these components.



18. Using 17mm socket, remove OEM output fitting (seen here in black) from port. In its place, install plug 1500718 using a 17mm socket. Torque plug to 74 ft-lbs.



BD ENGINE BRAKE, INC.

Plant Address: A10-33733 King Rd, Abbotsford, BC, Canada V2S 7M9

US Shipping Address: 88-446 Harrison St, Sumas, WA 98295 US Mailing Address: PO Box 231, Sumas, WA 98295

Phone: 604-853-6096 Fax: 604-853-8749 Internet: [www.bd-power.com](http://www.bd-power.com)

19. Remove OEM plug located adjacent to the output fitting using T50 Torx bit.

**Note:** Use care not to lose the ball bearing and spring found inside this port!

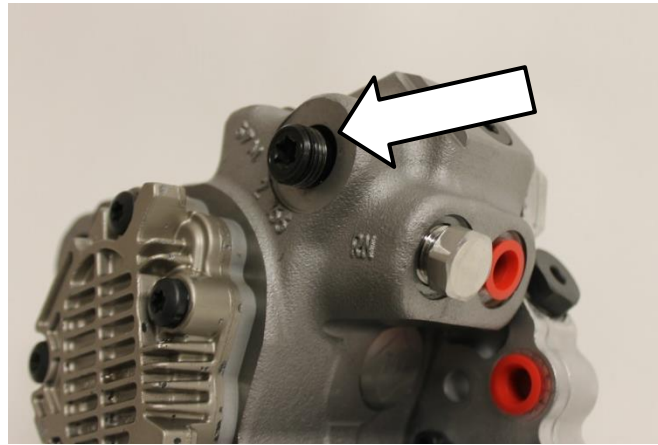

20. Carefully remove spring from OEM plug and install onto new output fitting F00N200499.



21. Install new output fitting with spring and ball bearing. Torque to 56 ft-lbs, using a 17mm socket.

**Note:** Ensure ball bearing is installed into port before installing fitting!



22. Mount CP3 pump to CP3 bracket 1500714. Use three(3) supplied 1453934 Bolts, six(6) 1401556 Washers, and three(3) FT-1190681 Nuts. Torque fasteners to 20 ft-lbs using a 13mm socket, and 13mm wrench.



23. Install supplied idler pulley DAY89094, followed by 1402609 Washer, then the FT-11115722 Bolt. Using a 13mm socket, torque fastener to 20 ft-lbs.

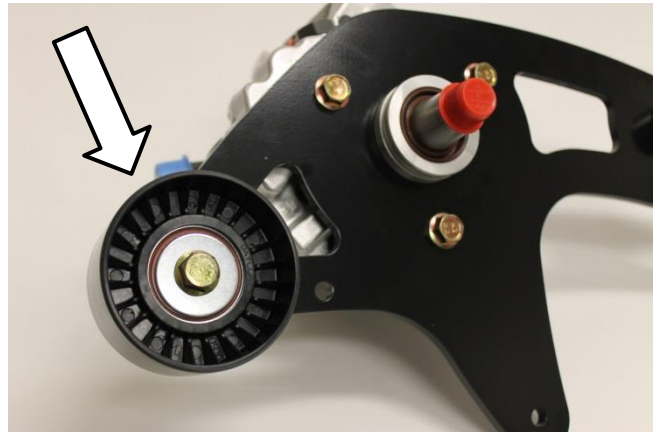

24. Install bracket and pump assembly onto the front of the engine. Using the OEM bolts from the cooling fan pulley hub. Using a 13mm socket, snug the bolts hand tight at this point.

**Note:** The wiring running along the coolant passage behind the pump may need to be pushed back to allow space.

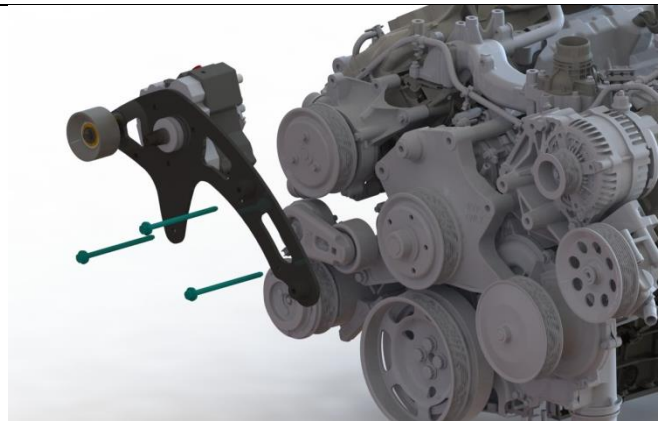



25. Insert stand-off 1500715 between CP3 bracket and engine, using the supplied longer OEM bolt W701629-S437.

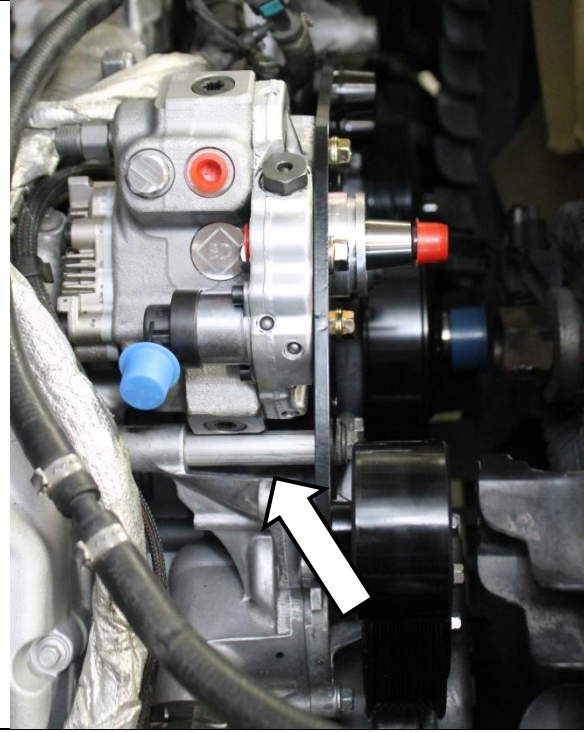

26. Torque all bolts from bracket to engine to 18 ft-lbs, using a 13mm socket. Excluding lower right hand bolt (see arrow). This bolt will be installed with the cooling fan assembly later.

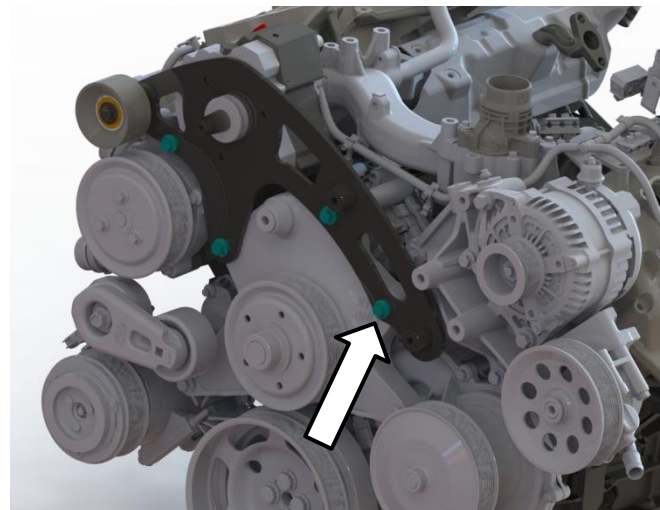

27. Install OEM idler pulleys as shown using OEM hardware. Using a 15mm socket, torque fasteners to 35 ft-lbs.

**Note:** If equipped from factory with grooved idler pulleys, use smooth pulleys from optional kit 1050470-SB, and install with OEM hardware.

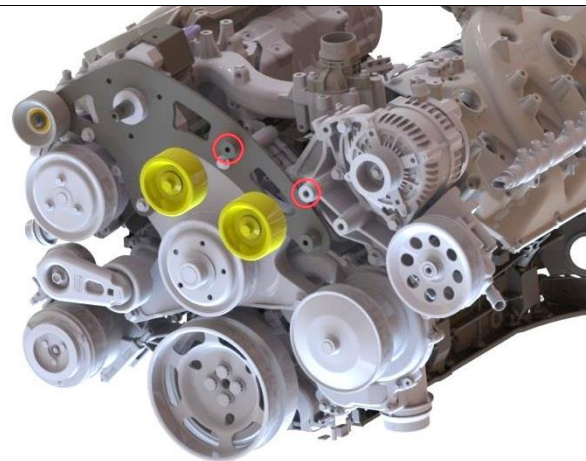

28. Install CP3 drive pulley 1500708 onto pump shaft with washer FT-40388 and jam nut FT-MJ2740000ZP00. Using a 27mm socket, torque nut to 75 ft-lbs.

**Note:** It may be easier to apply final torque to nut after serpentine belt has been installed.

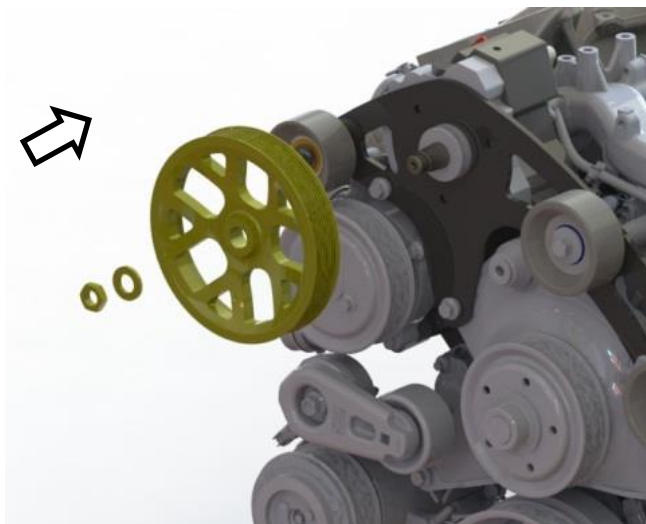

29. Ensure all pulleys are free running and have clearance. If interference exists, it may help to loosen bolts on main bracket and adjust position on engine.



30. Locate passenger side fuel rail, located above valve cover. Remove small plug located at the front of the rail using a 10mm 12 point bit (also known as a triple square).

**Note:** Clean area thoroughly before removing plug. Fuel injection equipment is manufactured to very precise tolerances and fine clearances. To prevent fuel system damage, it is essential that absolute cleanliness is observed.



BD ENGINE BRAKE, INC.

Plant Address: A10-33733 King Rd, Abbotsford, BC, Canada V2S 7M9

US Shipping Address: 88-446 Harrison St, Sumas, WA 98295 US Mailing Address: PO Box 231, Sumas, WA 98295

Phone: 604-853-6096 Fax: 604-853-8749 Internet: [www.bd-power.com](http://www.bd-power.com)

31. Install supplied fuel rail fitting 1500704, into previously plugged port (front end of passenger side fuel rail). Using a 22mm socket, torque to 75 ft-lbs.



32. Install supplied fuel line 1500716 between the installed fuel rail fitting, and the CP3 output fitting. Torque both ends to 30 ft-lbs using 19mm crows foot wrench.

**Note:** Ensure both ends of the fuel line are seated before applying final torque. To perfectly align both ends of fuel line, a small amount of bending adjustment may be required.



33. Route OEM CP4 pump wiring behind installed CP3 pump as shown.

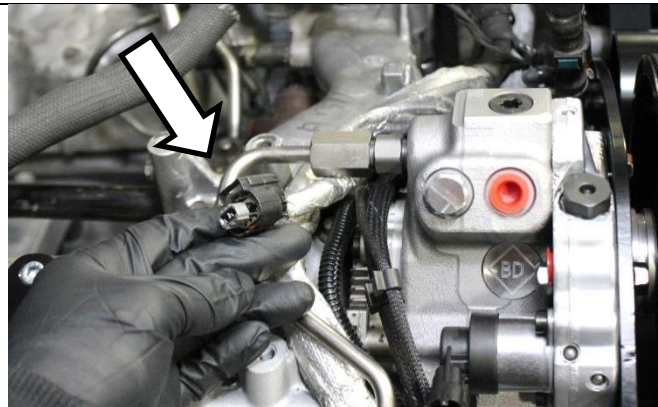

BD ENGINE BRAKE, INC.

Plant Address: A10-33733 King Rd, Abbotsford, BC, Canada V2S 7M9

US Shipping Address: 88-446 Harrison St, Sumas, WA 98295 US Mailing Address: PO Box 231, Sumas, WA 98295

Phone: 604-853-6096 Fax: 604-853-8749 Internet: [www.bd-power.com](http://www.bd-power.com)

34. Plug-in supplied wiring harness 1500722 into OEM CP4 connector, and CP3 as shown.

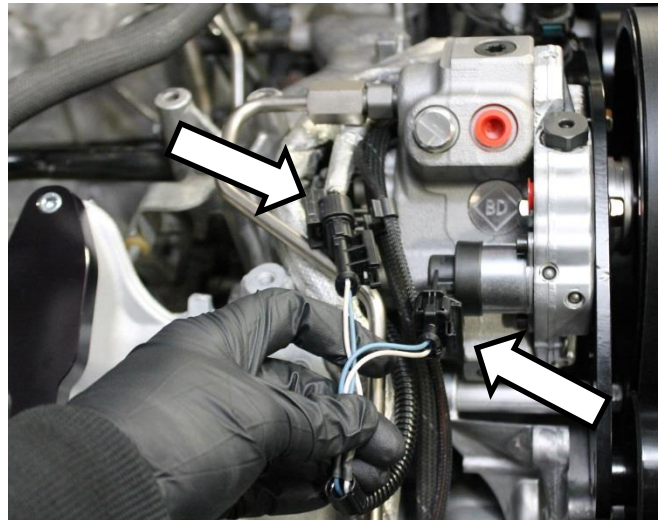

35. Loop supplied harness around toward OEM CP4 pump, and pull underneath coolant crossover passage. Plug harness into OEM CP4 pump.

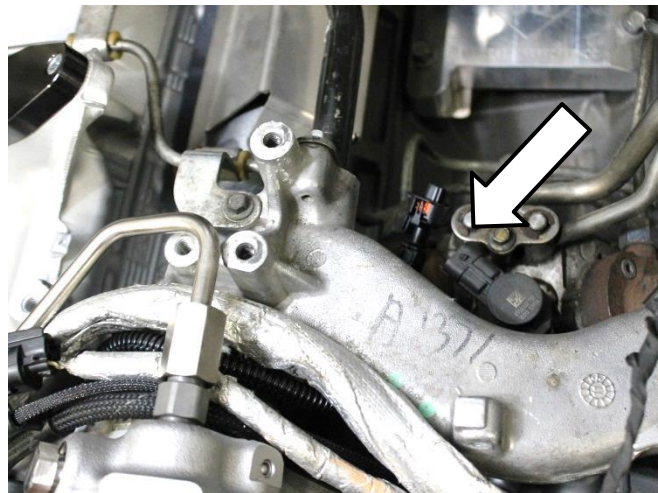

36. Route harness and wiring behind CP3 pump, and ensure wiring is not directly contacting exhaust manifolds, or any other hot surface.

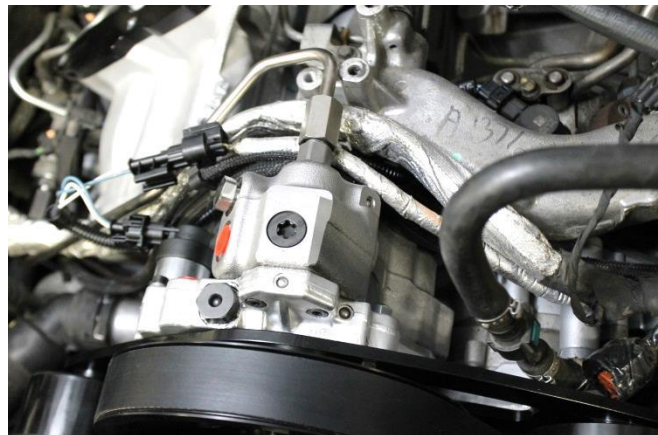

BD ENGINE BRAKE, INC.

Plant Address: A10-33733 King Rd, Abbotsford, BC, Canada V2S 7M9

US Shipping Address: 88-446 Harrison St, Sumas, WA 98295 US Mailing Address: PO Box 231, Sumas, WA 98295

Phone: 604-853-6096 Fax: 604-853-8749 Internet: [www.bd-power.com](http://www.bd-power.com)

37. Remove the OEM CP3 inlet fitting and transfer the sealing washer over to the new 1502040 HiFlow fitting as shown.



38. Install 1502040 HiFlow pressure feed fitting sealing washer, and torque to 6 ft-lbs.

**Note:** High flow fitting has a thin wall and may fracture if over-torqued. Do not exceed specified torque values!

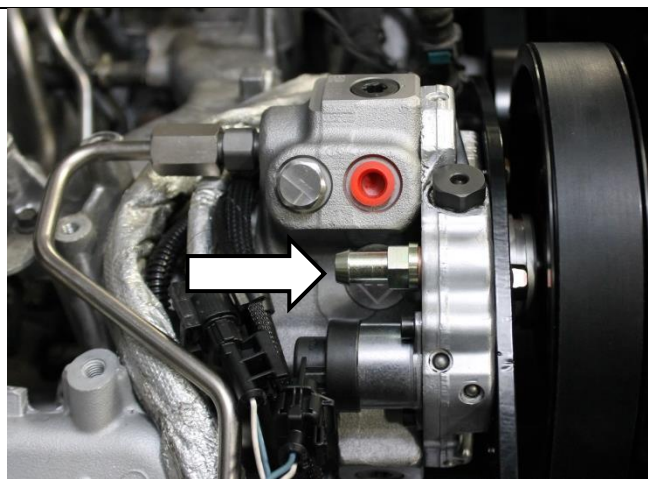

39. Install 1500728 Banjo fitting, 1502015 Banjo bolt, and 1502019 seal washers. Assemble hand tight as shown.

**Note:** Fitting will be tightened and positioned when hose is installed.

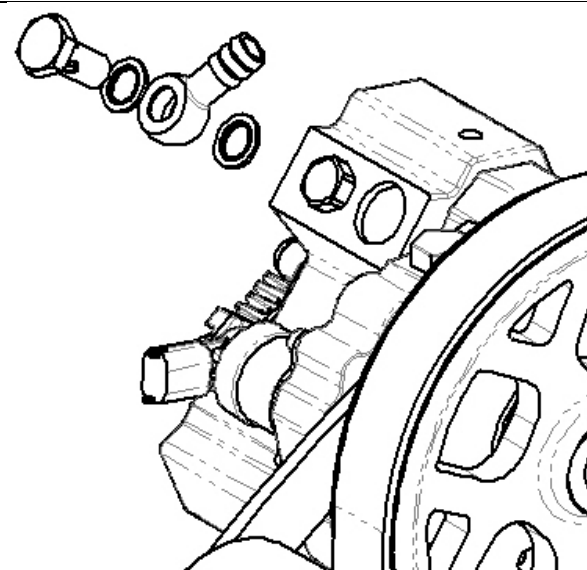

40. Install supplied serpentine belt GATK081298. Route as shown in the accompanying image. Install is reverse of removal.

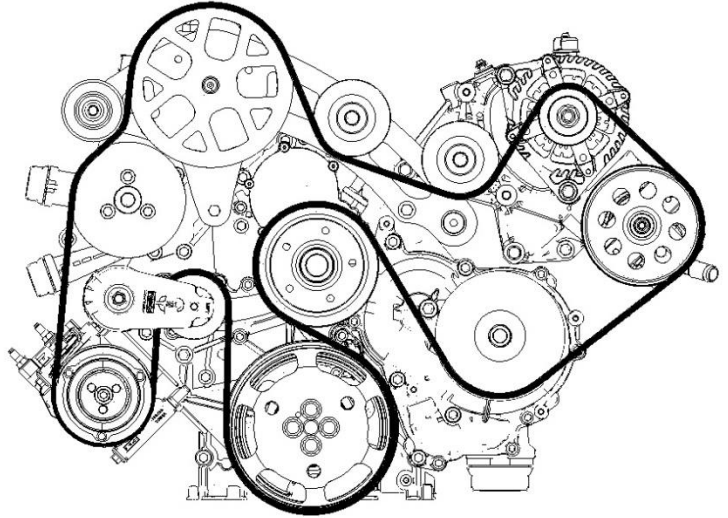

41. Before installing cooling fan assembly it may be helpful to adjust OEM fan connector bracket by bending the metal tab slightly forward as shown. This is done to accommodate the installed CP3 bracket thickness.



42. Re-install OEM fan connector bracket to fan clutch.

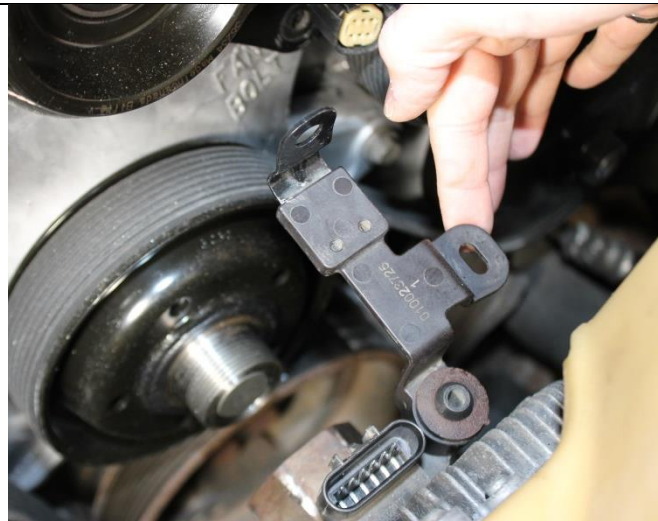

43. Re-install cooling fan, and torque to 98 ft-lbs (May require use of fan clutch wrench).

**Note:** It's helpful to have fan connector bracket bolt inserted into its respective hole, while installing cooling fan.



44. Torque fan bracket bolt to 18 ft-lbs, using a 13mm socket and reconnect fan clutch connector.

**Note:** Ensure fan brackets and connector do not interfere with serpentine belt or pulleys. There should be at least a fingers width clearance.

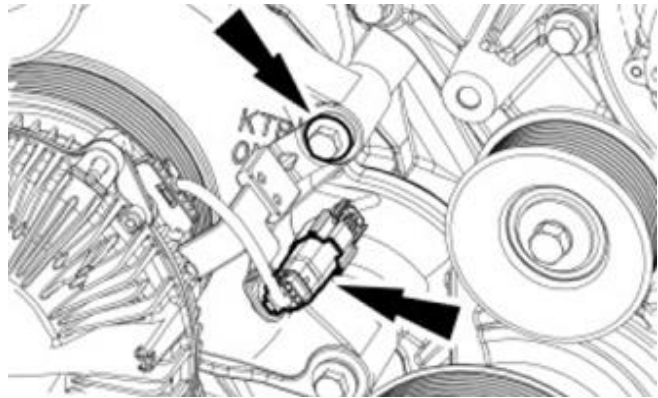

45. Re-install fan stator using three(3) of the OEM fasteners, as shown. Using a 13mm socket, torque to 12.5 ft-lbs (150 in-lbs). Skipping upper passenger side mount.

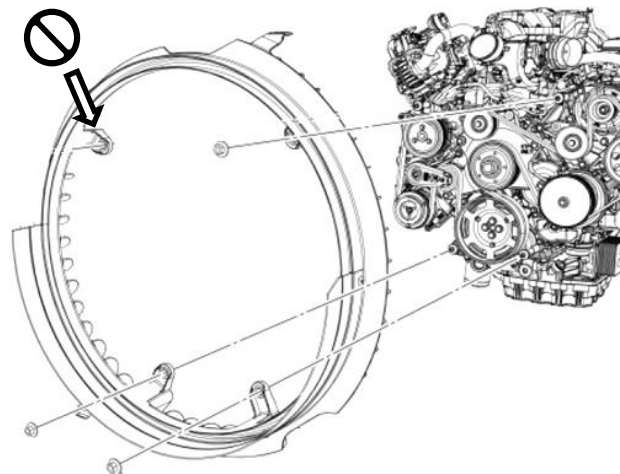

BD ENGINE BRAKE, INC.

Plant Address: A10-33733 King Rd, Abbotsford, BC, Canada V2S 7M9

US Shipping Address: 88-446 Harrison St, Sumas, WA 98295 US Mailing Address: PO Box 231, Sumas, WA 98295

Phone: 604-853-6096 Fax: 604-853-8749 Internet: [www.bd-power.com](http://www.bd-power.com)

46. Using 1601711 fastener, temporarily install supplied 1500725 stator support bracket onto the passenger side upper stator mount. This replaces support for upper passenger side.

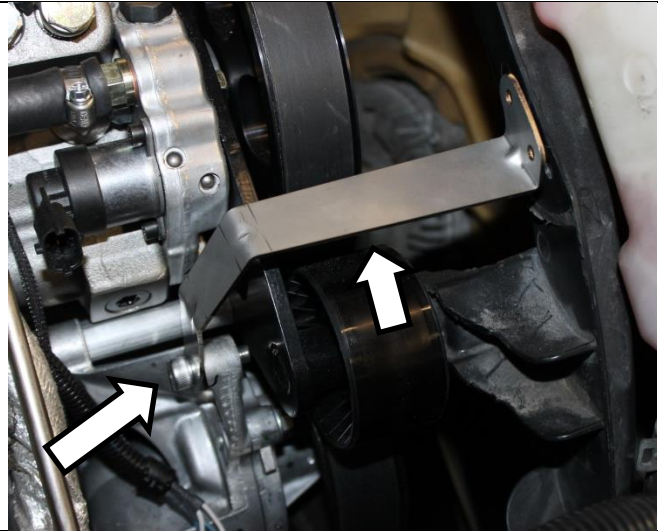

Mark fan stator through holes on 1500725 bracket, and then remove for drilling holes.



47. Drill two(2) 6mm(.236in) diameter holes on marks made in previous step.

**Note:** It is helpful to use a step drill bit for drilling plastic stator.

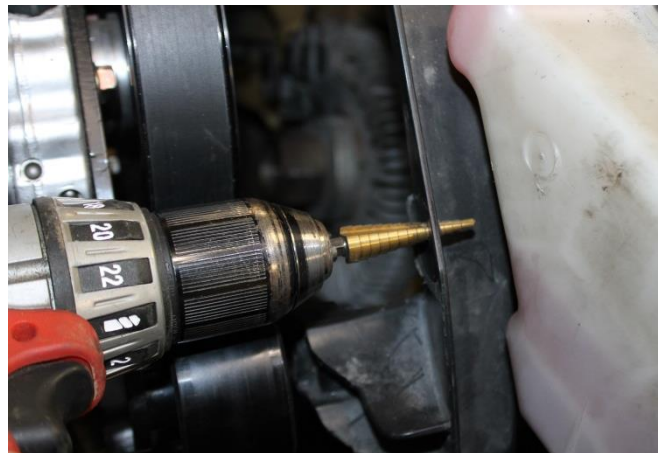



48. Re-install the 1500725 bracket using supplied 1601711 fastener, and two(2) GEN-19639 push pins on the fan stator.  
Torque fastener to 15 ft-lbs using 6mm hex drive.



49. **Note:** Some clearance of fan stator may be required for pulley clearance. This can be done with a Dremel, or small saw.

50. Assemble an FT-0424777 O-ring onto each 1500721 ORB adapter as shown.

**Note:** Use care not to cut or damage O-ring!

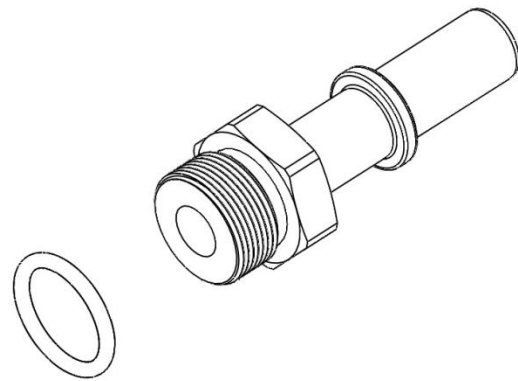

51. Insert two(2) FT-99604842 O-rings into each 1500719 quick-disconnect adapter. They are installed into the internal O-ring grooves inside the large end.

**Note:** Can be helpful to use a small flat blade screwdriver.

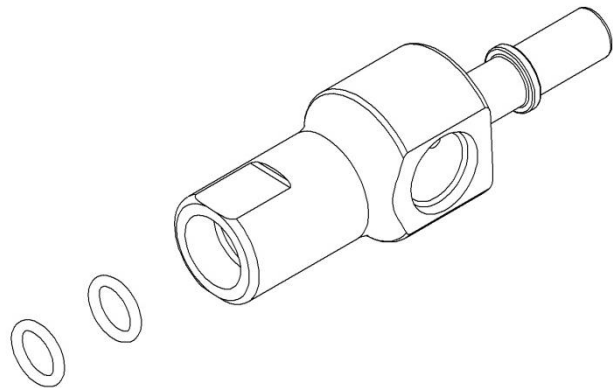

52. Install a 1500721 ORB adapter with O-ring into each 1500719 quick-disconnect adapter as shown. Torque to 15 ft-lbs, using 7/8in wrench.

**Note:** Apply FT-0606434 Loctite to threads

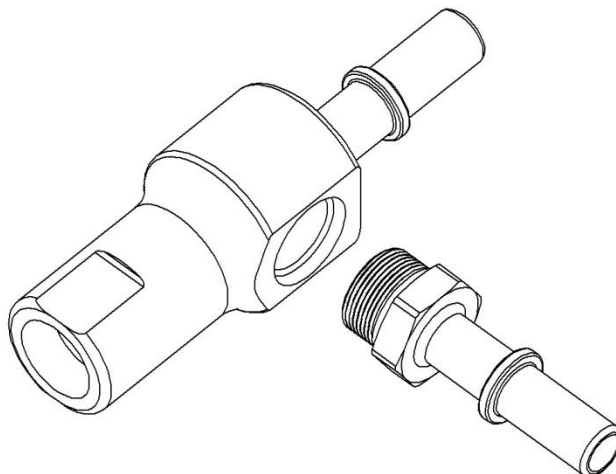

Using 4-1/2 in of supplied 1/2in hose, use 1452821 gear clamps to secure a 1500727 quick-disconnect fitting in each end as shown.

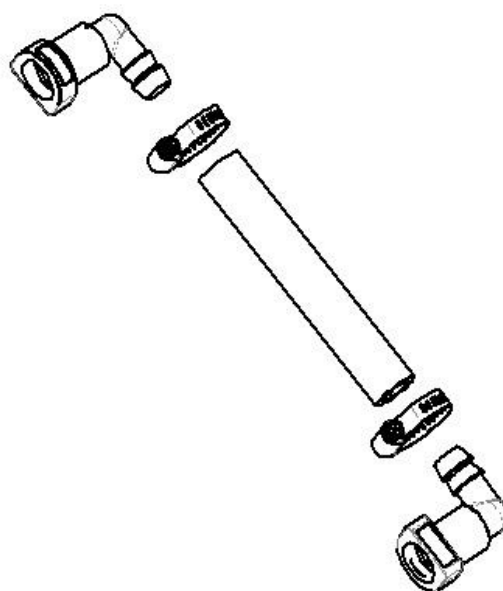

Remove OEM fuel tube assembly, by pinching tabs together on quick-disconnects, and pulling up on colored collars.

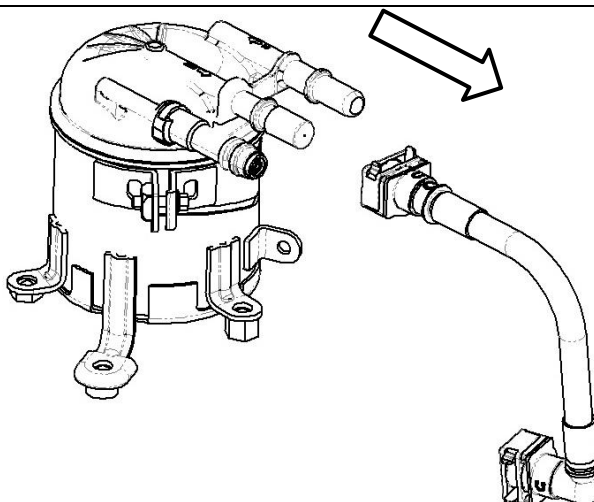

BD ENGINE BRAKE, INC.

Plant Address: A10-33733 King Rd, Abbotsford, BC, Canada V2S 7M9

US Shipping Address: 88-446 Harrison St, Sumas, WA 98295 US Mailing Address: PO Box 231, Sumas, WA 98295

Phone: 604-853-6096 Fax: 604-853-8749 Internet: [www.bd-power.com](http://www.bd-power.com)

53. Install a pre-assembled quick-disconnect adapter (arrow 2) onto OEM fuel filter outlet, in place of fuel tube assembly.

Apply FT-0606434 Loctite to 1500720 retaining collar (arrow 1), and slide over outlet, behind shoulder, and thread into adapter. Torque to 10 ft-lbs.

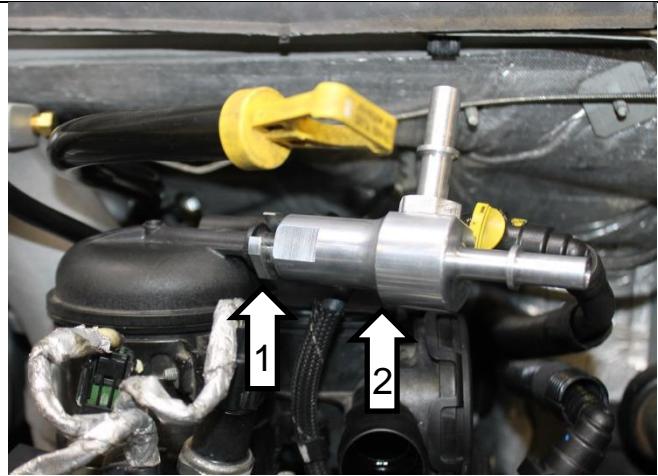

54. **Note:** It's helpful to put a small amount of diesel fuel onto o-rings, and/or fuel filter outlet to assist assembly.

55. Install new pre-assembled fuel tube between quick-disconnect adapter, and fuel pump feed inlet.

56. **Note:** A small amount of diesel fuel on o-rings can help install here as well.

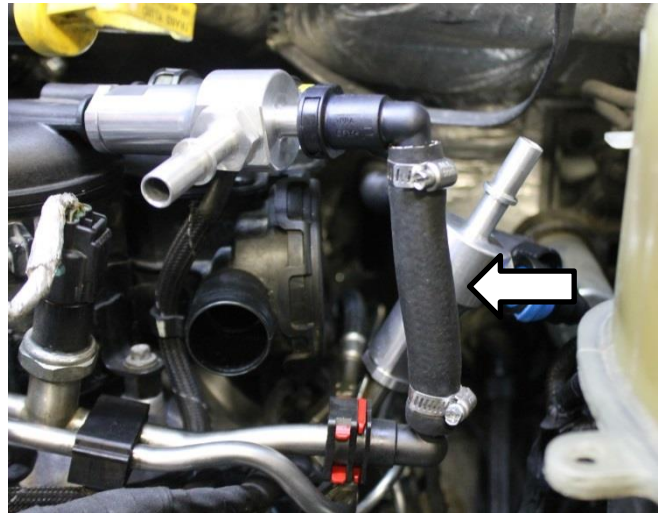

57. Locate OEM fuel return quick-disconnect (seen here with blue latch), and remove.

This is done by lifting the locking collar and depressing tab while pulling up.



58. Install second quick-disconnect adapter onto return outlet (arrow 2). Apply FT-0606434 Loctite to 1500720 retaining collar (arrow 1), and slide over outlet, behind shoulder, and thread into adapter. Torque to 10 ft-lbs.

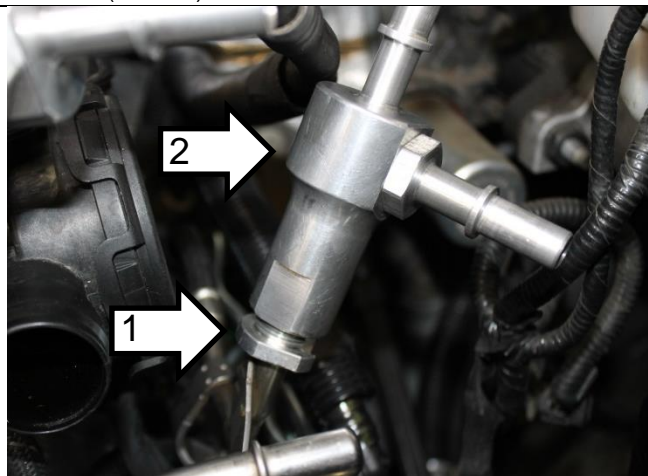

Plug OEM fuel return line onto quick-disconnect adapter as shown, and depress locking collar.



Insert 1500723 quick-disconnect fitting into end of supplied 1/2in fuel hose, and secure with 1452821 gear clamp.

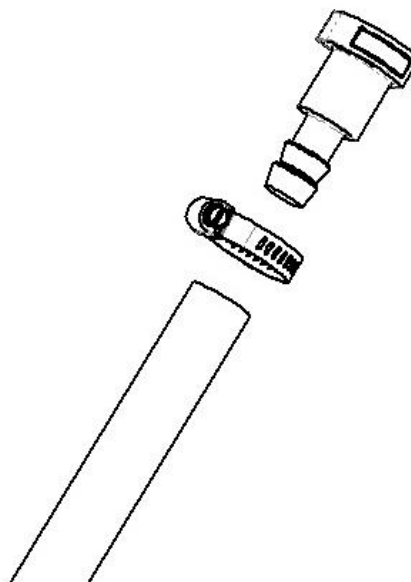

59. Connect hose to quick-disconnect adapter located on fuel filter, and route fuel tube towards CP3 pump feed fitting.



60. Trim to length and push hose over feed fitting on CP3 pump. Secure with 1452821 gear clamp.

61. **Note:** Ensure fuel hose is clear of moving parts, or hot engine components.

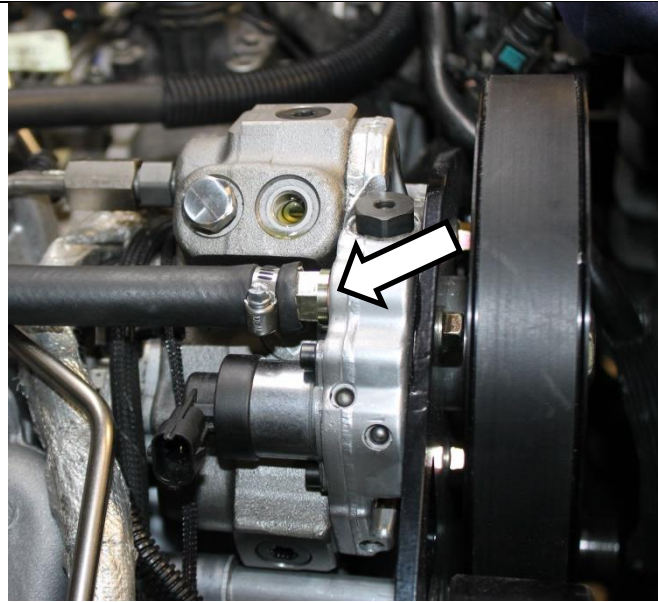

62. Insert 1500727 quick-disconnect fitting into end remaining supplied 1/2in fuel hose, and secure with 1500387 spring clamp.

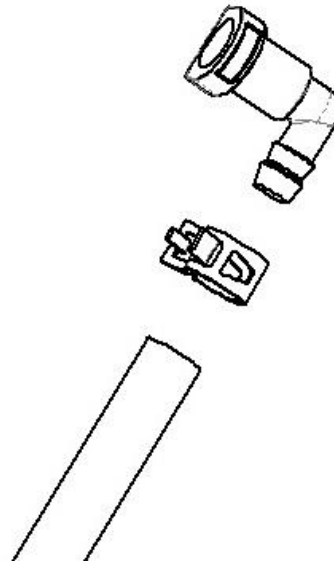

BD ENGINE BRAKE, INC.

Plant Address: A10-33733 King Rd, Abbotsford, BC, Canada V2S 7M9

US Shipping Address: 88-446 Harrison St, Sumas, WA 98295 US Mailing Address: PO Box 231, Sumas, WA 98295

Phone: 604-853-6096 Fax: 604-853-8749 Internet: [www.bd-power.com](http://www.bd-power.com)

Connect hose to quick-disconnect adapter with OEM return line, and route fuel tube towards CP3 pump return banjo fitting.

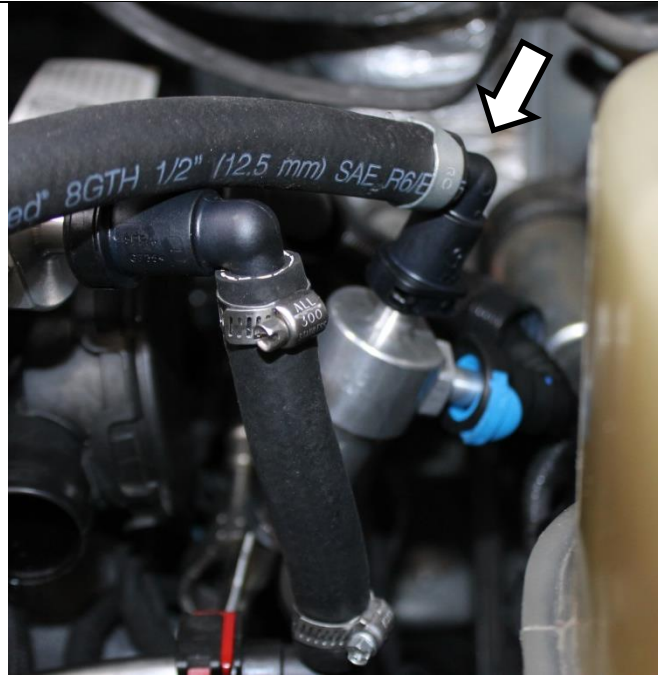

63. Trim fuel tube to length, and secure with 1500387 spring clamp. Tighten banjo bolt to 18 ft-lbs using 3/4in socket.

64. **Note:** Clock banjo fitting to ensure return hose does not contact any moving or hot engine parts.

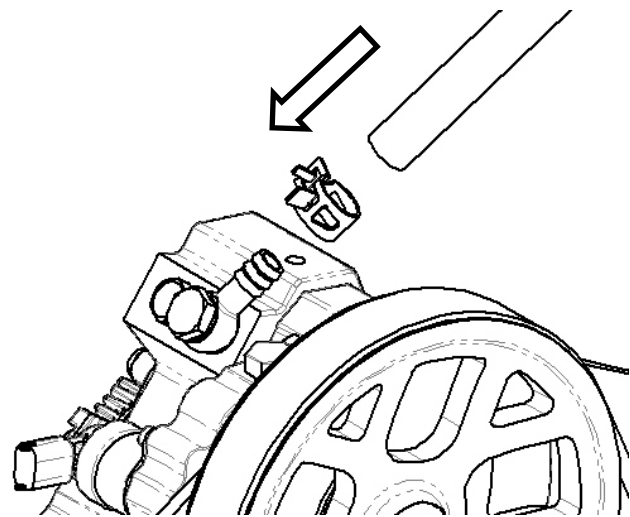

65. Re-install intake tube, and any other components removed for install of pump.

66. **Note:** Double check fasteners and fittings to ensure all joints and connections are tight.



BD ENGINE BRAKE, INC.

Plant Address: A10-33733 King Rd, Abbotsford, BC, Canada V2S 7M9

US Shipping Address: 88-446 Harrison St, Sumas, WA 98295 US Mailing Address: PO Box 231, Sumas, WA 98295

Phone: 604-853-6096 Fax: 604-853-8749 Internet: [www.bd-power.com](http://www.bd-power.com)

67. Prime fuel system several times using the filter pump, or lift pump and start engine. Check for leaks.

### **OPERATION INSTRUCTIONS**

Once all parts are installed, the vehicle will require custom tuning to operate both high pressure fuel pumps together.

### **SPECIAL NOTES**

When adding a second high pressure injection pump, the demand for fuel flow from the factory lift pump will increase. Elevated horsepower levels may require an upgraded lift pump to support the additional CP3 fuel requirements.

**If you have any technical difficulties, concerns, comments, or complaints, please phone our Technical Support hotline at (800) 887-5030 between 8:30am-5:00pm PST (Pacific Standard Time) Monday to Friday.**

BD ENGINE BRAKE, INC.

Plant Address: A10-33733 King Rd, Abbotsford, BC, Canada V2S 7M9

US Shipping Address: 88-446 Harrison St, Sumas, WA 98295 US Mailing Address: PO Box 231, Sumas, WA 98295

Phone: 604-853-6096 Fax: 604-853-8749 Internet: [www.bd-power.com](http://www.bd-power.com)