



**DOWNLOAD ENHANCED  
INSTALL MANUALS AT  
*dieselperformance.com***











# **FLOWMAX MONSTER LINE KIT**

## **Installation Instructions**

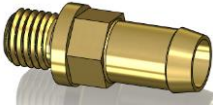
**P/N # 1050331**

**PLEASE READ ALL INSTRUCTIONS CAREFULLY BEFORE INSTALLATION.**

**Kit Contents:**

1502033	1502038	1502040	1452821	1500313
				
<i>M12 to -8JIC Adapter</i>	<i>-8 JICF to 1/2" Barb 90</i>	<i>HiFlow CP3 Fitting</i>	<i>Hose Clamp 1"</i>	<i>-8 ORB x 1/2" Barb</i>
<b>Qty: 1</b>	<b>Qty: 1</b>	<b>Qty: 1</b>	<b>Qty: 6</b>	<b>Qty: 1</b>
1500313 - M	1500380	1300131	1604054	
				
<i>1/2" Filter Fitting</i>	<i>1/2" Quick Connect</i>	<i>Tie Wrap</i>	<i>1/2" Fuel Hose</i>	
<b>Qty: 1</b>	<b>Qty: 1</b>	<b>Qty: 6</b>	<b>Qty: 168"</b>	

**Optional Accessories:**

- 1050330 – Fuel Sump Kit
- 1050345 – High Flow 5/8" Draw Straw Kit

**Required Tools:**

- Socket Set
- Phillips Screwdriver
- 1/2" Quick connect removal tool
- In-lb torque wrench
- Box Cutter
- Knife To Cut Fuel Hose
- Flat nose pliers
- Flat Screwdriver

BD Engine Brake Inc.

Plant Address: 33541 MacLure Rd. Abbotsford, BC, Canada V2S 7W2

U.S. Shipping Address: 88-446 Harrison St, Sumas, WA 98295 U.S. Mailing Address: P.O. Box 231, Sumas, WA 98295

Phone: 604-853-6096 | Fax: 604-853-8749 | Internet: www.bd-power.com

## Dodge Applications

**NOTE: The vehicle must have an aftermarket fuel filtration device such as the Flowmax Filter Kit (1050340-PFF) to bypass the O.E. filter bowl.**

### SIDE FEED CP3 INSTALLATION (5.9L Trucks)

1. Remove supply line from the CP3 pump by unthreading the 17mm banjo fitting (Shown with Arrow).
2. If complete removal of the supply line is desired, unthread the return fitting as well and remove the hard line.



3. Insert the M12 to -8JIC (1502033) adapter and torque to **6ft-lb (72in-lb)**.



BD Engine Brake Inc.

Plant Address: 33541 MacLure Rd. Abbotsford, BC, Canada V2S 7W2

U.S. Shipping Address: 88-446 Harrison St, Sumas, WA 98295 U.S. Mailing Address: P.O. Box 231, Sumas, WA 98295

Phone: 604-853-6096 | Fax: 604-853-8749 | Internet: [www.bd-power.com](http://www.bd-power.com)

4. Now thread the 8JICF to 90 Hose barb (1502038) onto the JIC fitting and tighten with an open end wrench. Tighten the pair of fittings until the lower M12 fitting just begins to turn and then stop.



5. Push 1/2" hose over hose barb and tighten with hose clamp.
6. Now, route 1/2" hose to the outlet of your fuel lift pump using supplied zip-ties. Take caution to avoid any chafing or hot areas that may burn the hose.



BD Engine Brake Inc.

Plant Address: 33541 MacLure Rd. Abbotsford, BC, Canada V2S 7W2

U.S. Shipping Address: 88-446 Harrison St, Sumas, WA 98295 U.S. Mailing Address: P.O. Box 231, Sumas, WA 98295

Phone: 604-853-6096 | Fax: 604-853-8749 | Internet: [www.bd-power.com](http://www.bd-power.com)

7. If using a BD Flowmax pump. Thread supplied 1/2" barb fitting into the pump inlet and secure with a hose clamp, cut hose to length as necessary.

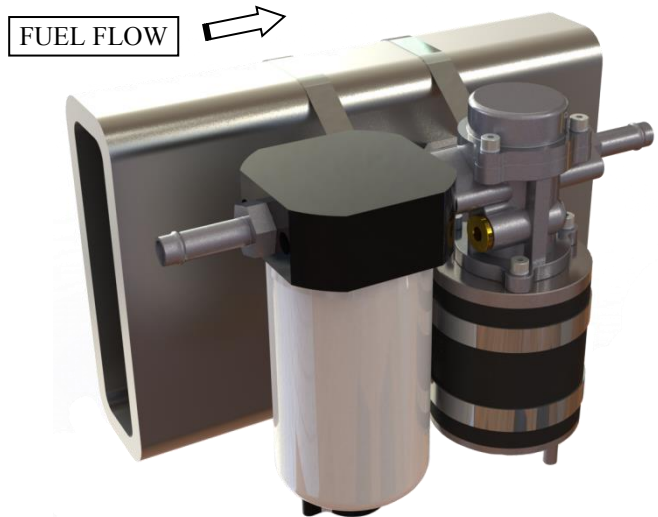
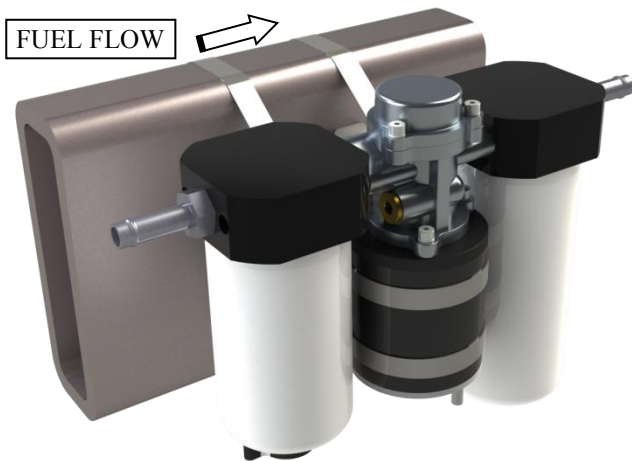

***If your setup has a water separator in between the tank and the flowmax pump. The filter fitting screen will need to be removed by pulling it out with a set of pliers.***



**REAR FEED CP3 INSTALLATION (6.7L Trucks)**

1. Remove the quick connect fitting from the fuel supply line by pinching the tabs inward and pulling the connector off.



2. Now remove the CP3 inlet fitting and place beside the HiFlow CP3 fitting.
3. Remove the O-ring from the base of the O.E. fitting and transfer to the HiFlow fitting as shown.



BD Engine Brake Inc.

Plant Address: 33541 MacLure Rd. Abbotsford, BC, Canada V2S 7W2

U.S. Shipping Address: 88-446 Harrison St, Sumas, WA 98295 U.S. Mailing Address: P.O. Box 231, Sumas, WA 98295

Phone: 604-853-6096 | Fax: 604-853-8749 | Internet: [www.bd-power.com](http://www.bd-power.com)

4. Once the O-ring is switched over, thread the HiFlow fitting into the CP3 inlet. **Torque the fitting to 6ft-lb (72in-lb).**

**NOTE:** THE HIFLOW FITTING HAS A THIN WALL AND MAY FRACTURE IF OVER-TORQUED. DO NOT EXCEED SPECIFIED TORQUE VALUES



5. Push 1/2" fuel hose over the HiFlow barb and secure tightly with supplied hose clamp.
6. Now, route 1/2" hose to the outlet of your fuel lift pump using supplied zip-ties. Take caution to avoid any chafing or hot area that may burn the hose.



BD Engine Brake Inc.

Plant Address: 33541 MacLure Rd. Abbotsford, BC, Canada V2S 7W2

U.S. Shipping Address: 88-446 Harrison St, Sumas, WA 98295 U.S. Mailing Address: P.O. Box 231, Sumas, WA 98295

Phone: 604-853-6096 | Fax: 604-853-8749 | Internet: [www.bd-power.com](http://www.bd-power.com)

7. If using a BD Flowmax pump. Thread supplied 1/2" barb fitting into the pump inlet and secure with a hose clamp, cut hose to length as necessary.

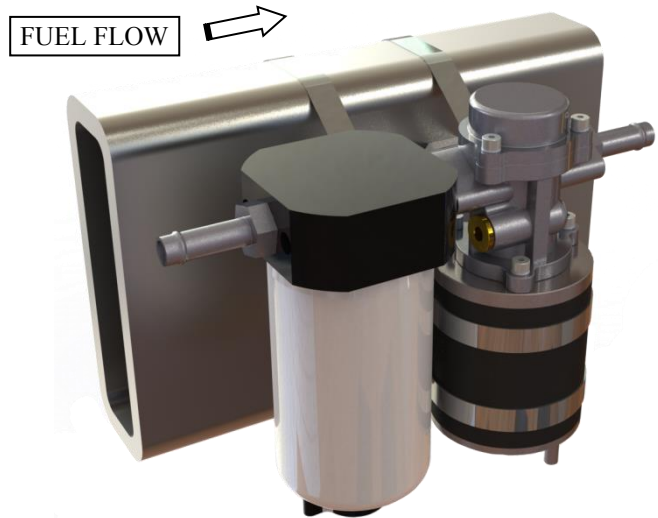
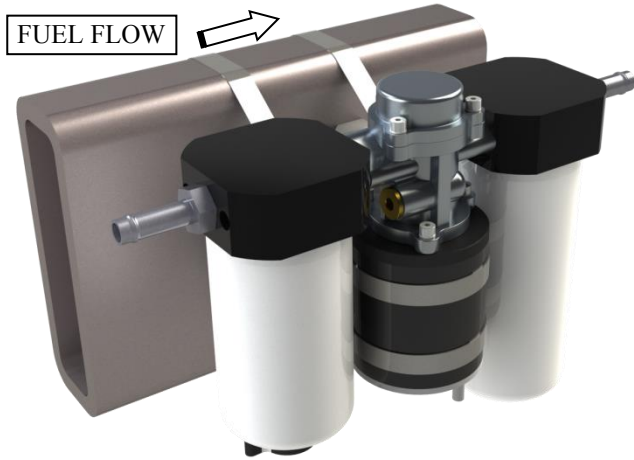

***If your setup has a water separator in between the tank and the flowmax pump. The filter fitting screen will need to be removed by pulling it out with a set of pliers.***





## GM Applications

**NOTE: The vehicle must have an aftermarket fuel filtration device such as the Flowmax Filter Kit (1050340-PFF) to bypass the O.E. filter bowl.**

**NOTE: 2005 and older trucks MUST route fuel through the FICM for cooling purposes.**

1. Begin by placing a drain pan below the truck and draining about a gallon of coolant out. The drain plug can usually be found on the passenger side at the base of the radiator.

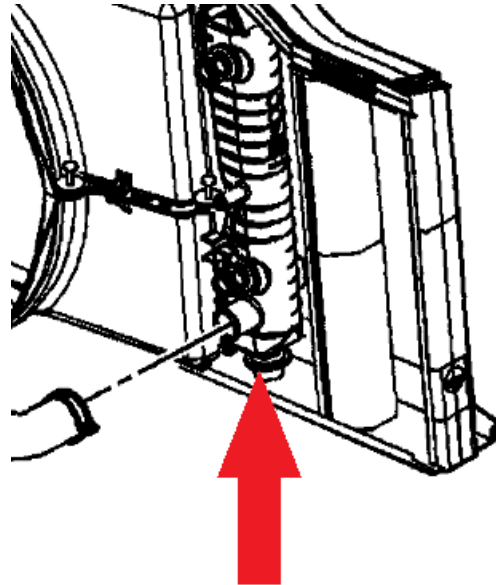

2. While the coolant is draining, remove the upper intake and intake silencer/engine cover.

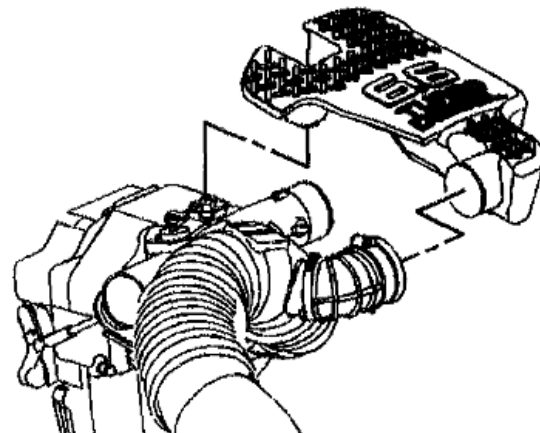

BD Engine Brake Inc.

Plant Address: 33541 MacLure Rd. Abbotsford, BC, Canada V2S 7W2

U.S. Shipping Address: 88-446 Harrison St, Sumas, WA 98295 U.S. Mailing Address: P.O. Box 231, Sumas, WA 98295

Phone: 604-853-6096 | Fax: 604-853-8749 | Internet: [www.bd-power.com](http://www.bd-power.com)



3. Unscrew the band clamp and remove the turbocharger coolant supply line from the hose nipple.



4. Now remove the steel coolant pipe from the top of the motor.

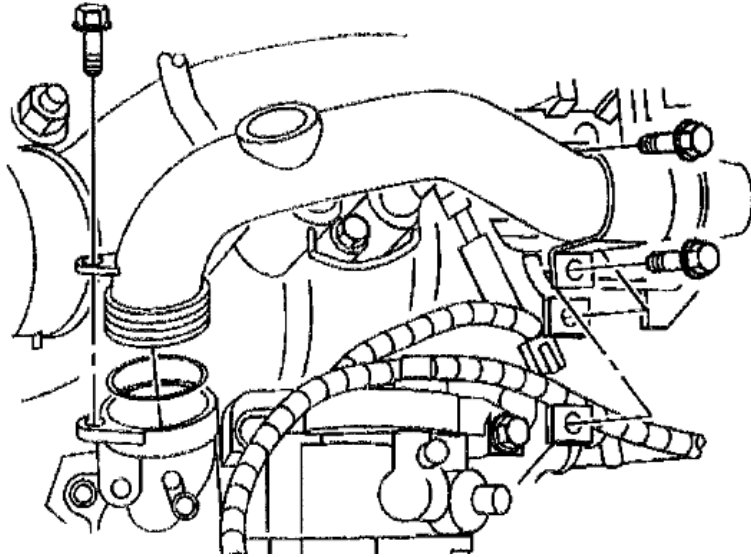

5. Looking down in the valley, the CP3 inlet fitting should be visible. Remove the hose clamp and pull off the inlet hose.



BD Engine Brake Inc.

Plant Address: 33541 MacLure Rd. Abbotsford, BC, Canada V2S 7W2

U.S. Shipping Address: 88-446 Harrison St, Sumas, WA 98295 U.S. Mailing Address: P.O. Box 231, Sumas, WA 98295

Phone: 604-853-6096 | Fax: 604-853-8749 | Internet: [www.bd-power.com](http://www.bd-power.com)

6. Remove the CP3 inlet fitting and transfer the sealing washer over to the new HiFlow fitting as shown.



7. Once the washer is switched over, thread the HiFlow fitting into the CP3 inlet. **Torque the fitting to 6ft-lb (72in-lb).**

**NOTE:** THE HIFLOW FITTING HAS A THIN WALL AND MAY FRACTURE IF OVERTORQUED. DO NOT EXCEED SPECIFIED TORQUE VALUES



BD Engine Brake Inc.

Plant Address: 33541 MacLure Rd. Abbotsford, BC, Canada V2S 7W2

U.S. Shipping Address: 88-446 Harrison St, Sumas, WA 98295 U.S. Mailing Address: P.O. Box 231, Sumas, WA 98295

Phone: 604-853-6096 | Fax: 604-853-8749 | Internet: www.bd-power.com

8. Remove the two stock fuel supply lines from the filter head to CP3 inlet. These are the lines with the arrow pointing away from the filter head (circled).



9. Remove the abrasion sleeve from the O.E. supply line and transfer it to the 1/2" fuel hose.



BD Engine Brake Inc.

Plant Address: 33541 MacLure Rd. Abbotsford, BC, Canada V2S 7W2

U.S. Shipping Address: 88-446 Harrison St, Sumas, WA 98295 U.S. Mailing Address: P.O. Box 231, Sumas, WA 98295

Phone: 604-853-6096 | Fax: 604-853-8749 | Internet: [www.bd-power.com](http://www.bd-power.com)

10. Push the 1/2" hose over the HiFlow barb and secure tightly with a socket.



11. Route the other end of the hose straight to the filter head outlet nipple and secure with a hose clamp, avoiding the EGR cooler if applicable.
12. If deleting the stock fuel filter, route the hose to the FICM outlet or fuel supply pipe.

**NOTE: TRUCKS WITH  
ENGINE MOUNTED  
FICM MUST NOT BE  
BYPASSED**



BD Engine Brake Inc.

Plant Address: 33541 MacLure Rd. Abbotsford, BC, Canada V2S 7W2

U.S. Shipping Address: 88-446 Harrison St, Sumas, WA 98295 U.S. Mailing Address: P.O. Box 231, Sumas, WA 98295

Phone: 604-853-6096 | Fax: 604-853-8749 | Internet: www.bd-power.com

13. Ensure the abrasion sleeve is in the correct position and the hose is secured properly to avoid leaks and chafing.



14. Using quick disconnect tool, remove the supply line on the rear driver's side of the engine. The turbo outlet boot may need removal to gain access.



BD Engine Brake Inc.

Plant Address: 33541 MacLure Rd. Abbotsford, BC, Canada V2S 7W2

U.S. Shipping Address: 88-446 Harrison St, Sumas, WA 98295 U.S. Mailing Address: P.O. Box 231, Sumas, WA 98295

Phone: 604-853-6096 | Fax: 604-853-8749 | Internet: [www.bd-power.com](http://www.bd-power.com)

15. Connect the supplied 1/2" barbed quick connector over the pipe.
16. Push the fuel supply hose over the barb and secure with a hose clamp.



BD Engine Brake Inc.

Plant Address: 33541 MacLure Rd. Abbotsford, BC, Canada V2S 7W2

U.S. Shipping Address: 88-446 Harrison St, Sumas, WA 98295 U.S. Mailing Address: P.O. Box 231, Sumas, WA 98295

Phone: 604-853-6096 | Fax: 604-853-8749 | Internet: [www.bd-power.com](http://www.bd-power.com)



17. Route the other end of the fuel hose down the frame rail and to the lift pump outlet. Securing with zip-ties as necessary.

18. If using a BD FlowMax pump. Thread supplied 1/2" barb fitting into the pump inlet and secure with a hose clamp, cut hose to length.

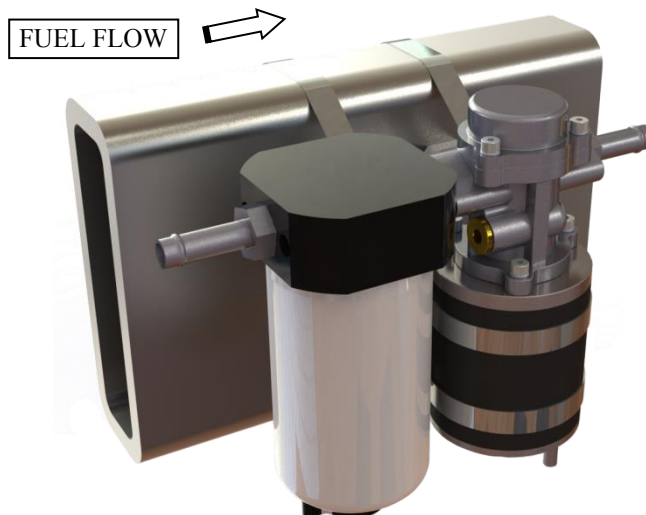
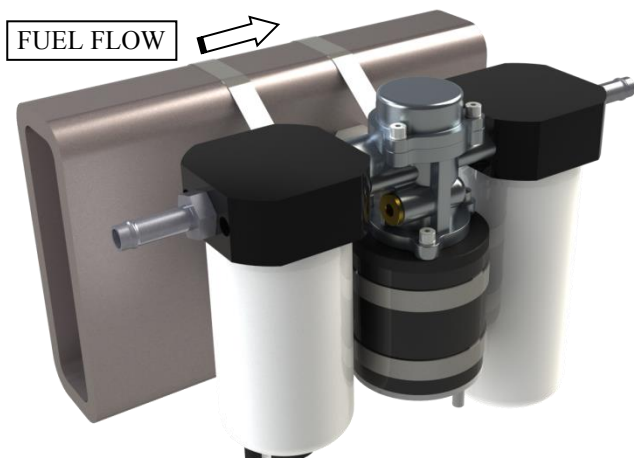

***If your setup has a water separator in between the tank and the flowmax pump. The filter fitting screen will need to be removed by pulling it out with a set of pliers.***



BD Engine Brake Inc.

Plant Address: 33541 MacLure Rd. Abbotsford, BC, Canada V2S 7W2

U.S. Shipping Address: 88-446 Harrison St, Sumas, WA 98295 U.S. Mailing Address: P.O. Box 231, Sumas, WA 98295

Phone: 604-853-6096 | Fax: 604-853-8749 | Internet: [www.bd-power.com](http://www.bd-power.com)

19. Reinstall the steel coolant pipe, turbo coolant line and engine intake system.

20. Prime the fuel system several times using the filter pump or lift pump and start the engine. Check for leaks.



BD Engine Brake Inc.

Plant Address: 33541 MacLure Rd. Abbotsford, BC, Canada V2S 7W2

U.S. Shipping Address: 88-446 Harrison St, Sumas, WA 98295 U.S. Mailing Address: P.O. Box 231, Sumas, WA 98295

Phone: 604-853-6096 | Fax: 604-853-8749 | Internet: [www.bd-power.com](http://www.bd-power.com)