



# DOWNLOAD ENHANCED INSTALL MANUALS AT [dieselperformance.com](http://dieselperformance.com)

#112494

## INJECTION PERFORMANCE MODIFICATION TO CUMMINS 6BTA5.9

### FUEL INJECTORS:

#### REMOVAL:

- 1: Disconnect both negative battery cables from both batteries.
- 2: Remove the high-pressure fuel lines. See High Pressure Fuel Line removal & installation.
- 3: Remove the fuel drain manifold. See Fuel Drain Manifold removal & installation.
- 4: Thoroughly clean the area around the injector.

**Caution:** When rust has formed on the fuel injector nut, (Fig 1) the injector (when being removed) can rotate in the cylinder head. This may cause damage to the cylinder head bore. Use a rust penetrating solvent before attempting to loosen a rusted holddown nut.

- 5: Hit the injector body with a brass drift to loosen it. (Fig 2).
- 6: Hold the injector body with one wrench while removing the injector nut with another. (Fig 3).
- 7: It may be necessary to tap the injector with an injector puller tool. (Fig 4)

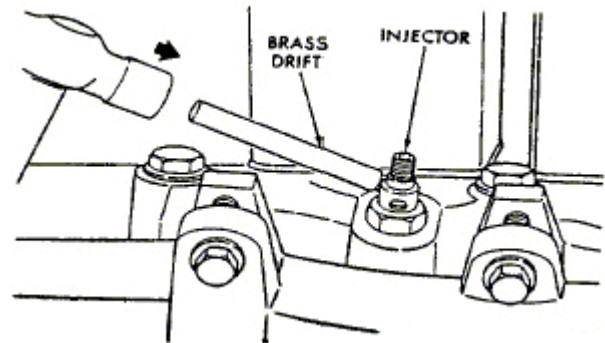

*Fig 2: Loosening Injector Body*

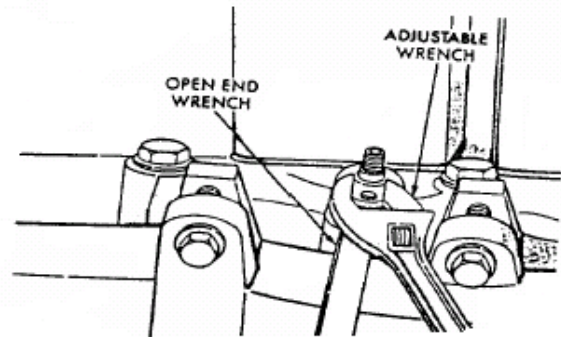

*Fig 3: Loosening injector*

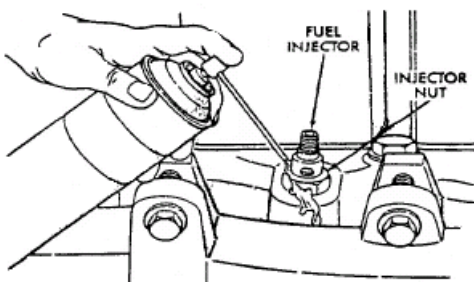

*Fig 1: Loosening Injector Nut*

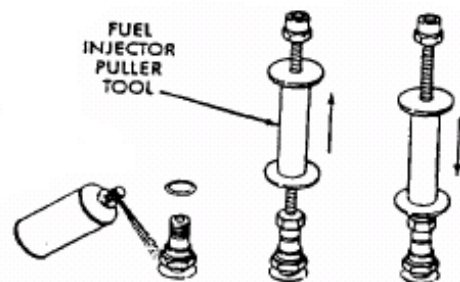

*Fig 4: Removing Injector with Puller Tool*

BD Engine Brake Inc.

Plant Address: 33541 MacLure Rd. Abbotsford, BC, Canada V2S 7W2

U.S. Shipping Address: 88-446 Harrison St, Sumas, WA 98295 U.S. Mailing Address: P.O. Box 231, Sumas, WA 98295

Phone: 604-853-6096 | Fax: 604-853-8749 | Internet: [www.bd-power.com](http://www.bd-power.com)

**\*\*\* PLEASE NOTE \*\*\***

---

***TIP WASHERS FOR INJECTORS***

Two different thicknesses of injector tip washers have been included in this kit. When installing the new injector washers, (re: figure #6) select the injector washers that are the same thickness as the used washers from the old injectors. Keeping in mind that the old washers have been crushed during the original installation, you will notice that the difference between thick and thin washers is quite evident.

It is also advisable that a performance air filter, such as a K&N or AFE brand, be installed to accommodate the extra constant airflow needed for the increase in power and boost. With automatic transmissions, the amount of variance between the torque curve of the engine and the reduction in the performance of the stock vehicle and the effect of the performance add-ons. The installation of a BD Performance torque converter is advisable to reduce the driveline slippage and greatly improve vehicle performance.

BD Engine Brake Inc.

Plant Address: 33541 MacLure Rd. Abbotsford, BC, Canada V2S 7W2

U.S. Shipping Address: 88-446 Harrison St, Sumas, WA 98295 U.S. Mailing Address: P.O. Box 231, Sumas, WA 98295

Phone: 604-853-6096 | Fax: 604-853-8749 | Internet: [www.bd-power.com](http://www.bd-power.com)

**INSTALLATION:**

1: Clean the injector cylinder head bore with special Cummins wire brush tool or equivalent (Fig 5)

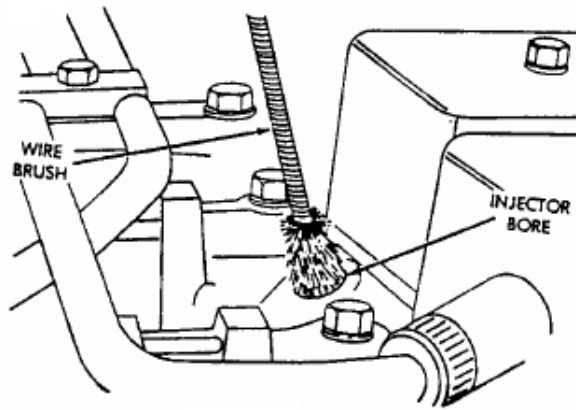

*Fig 5: Cleaning Cylinder Head Injector Bore*

2: Install a new copper washer on injector (Fig 6)

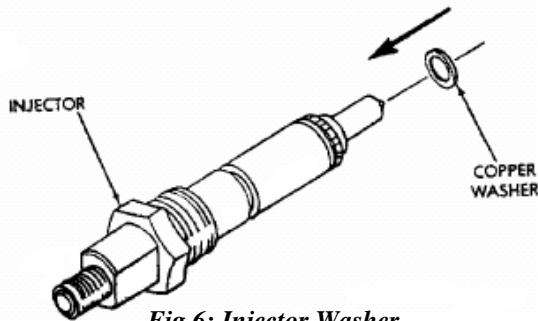

*Fig 6: Injector Washer*

3: Apply a coating of anti-seize compound to the threads of the injector holddown nut and between the top the nut and injector body (Fig 7).

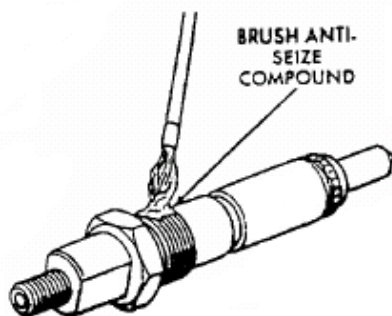

*Fig 7: Apply-Seize Compound*

4 Install the injector into the cylinder head. Align the tab on the injector to the notch in the cylinder bore (Fig 8). Certain types of injectors **may** have an o-ring located above the holddown nut (Fig 8). After

tightening the injector, push the o-ring into the groove the top of the injector.

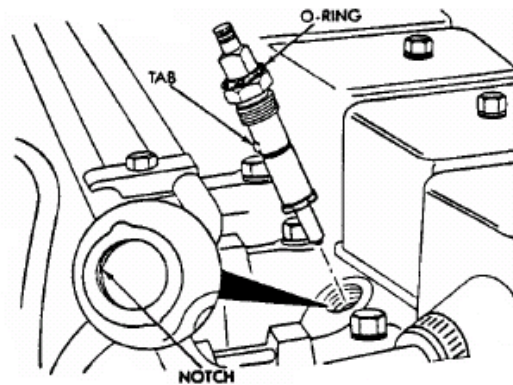

*Fig 8: Installing Injector*

5: Tighten the injector holddown nut to 60 N-m (44 ft. lbs.) torque.

6: Connect the fuel drain manifold to the injectors.

7: Connect the high-pressure fuel lines.

8. Connect the negative battery cables to both batteries.

9. Bleed the air from the high-pressure lines.

**HIGH-PRESSURE FUEL LINES:**

All high-pressure fuel lines are of the same length and inside diameter. Correct high-pressure fuel line usage and installation is critical to smooth engine operation.

**Caution: The high-pressure fuel lines must be clamped securely in place in the holders. The lines cannot contact each other or other components. Do not attempt to weld high-pressure fuel lines or to repair lines that are damaged. Only use the recommended lines when replacement of high-pressure fuel line is necessary.**

BD Engine Brake Inc.

Plant Address: 33541 MacLure Rd. Abbotsford, BC, Canada V2S 7W2

U.S. Shipping Address: 88-446 Harrison St, Sumas, WA 98295 U.S. Mailing Address: P.O. Box 231, Sumas, WA 98295

Phone: 604-853-6096 | Fax: 604-853-8749 | Internet: www.bd-power.com

**REMOVAL:**

- 1: Disconnect both negative battery cables from both batteries.
- 2: Remove the nameplate/cover from the top of the six engine valve covers (two nuts) (Fig 9)

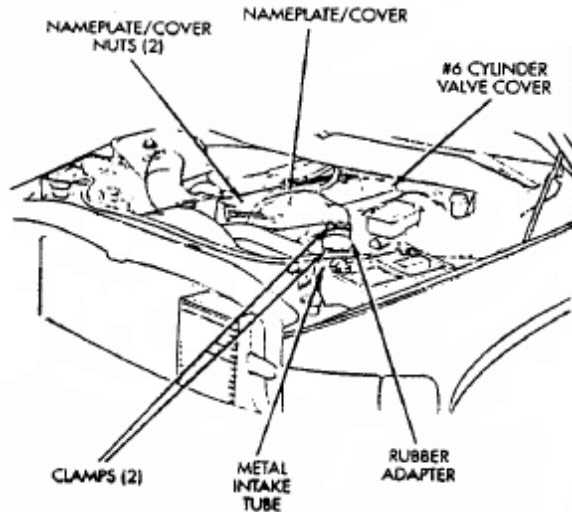

*Fig 9: Nameplate/Cover - Diesel*

- 3: Remove the necessary clamps holding the lines to the engine.
- 4: Clean the area around each line. Disconnect each line at the top of each fuel injector. (Fig 10)

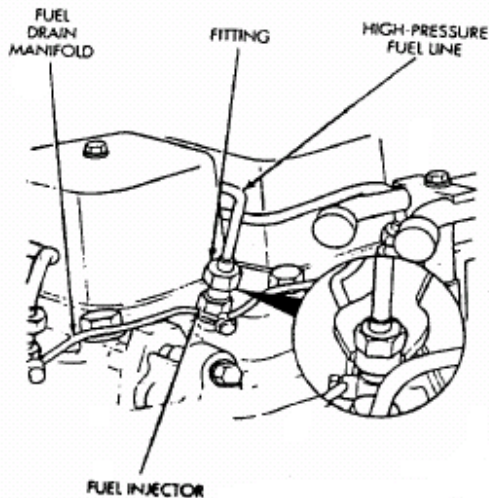

*Fig 10: Fuel Lines at Fuel Injectors*

**Caution:** Be sure that the high-pressure fuel lines are installed in the same order that they were removed. Prevent the injection pump delivery valve holders from turning when removing or installing high-pressure lines from injection pump.

- 5: Disconnect each high-pressure line fitting at each fuel injection pump delivery valve holder (Fig 11).

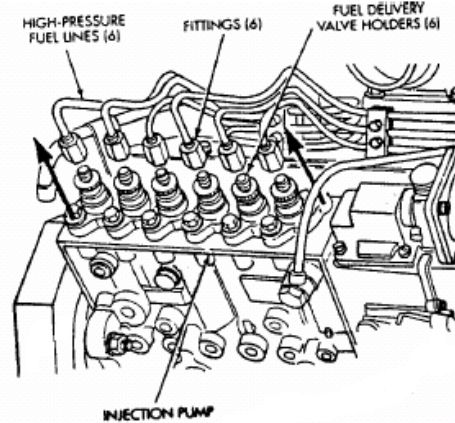

*Fig 11: Delivery Valve Holders and Pressure Lines*

- 6: Very carefully remove each line from the engine. **Do not bend the line while removing.**

**INSTALLATION:**

- 1: Carefully position each high-pressure fuel line to the fuel injector and fuel injection pump delivery valve holder in the correct firing order. Also position each line in the correct line holder.
- 2: Loosely install the line clamp isolator and bracket holder bolts.
- 3: Tighten each line at the delivery valve holder to 30 N-m (22 ft. lbs.) torque.
- 4: Tighten each line at the fuel injector to 30 N-m (22 ft. lbs.) torque.

**Be sure the lines are not contacting each other or any other component.**

- 5: Tighten the clamp bracket bolts to 24 N-m (18 ft. lbs.) torque.
- 6: Bleed air from the fuel system.

**FUEL DRAIN MANIFOLD****REMOVAL:**

- 1: Remove the two nuts retaining the nameplate/cover to the top of the six engine valve covers (Fig 12). Remove nameplate cover from the engine.

BD Engine Brake Inc.

Plant Address: 33541 MacLure Rd. Abbotsford, BC, Canada V2S 7W2

U.S. Shipping Address: 88-446 Harrison St, Sumas, WA 98295 U.S. Mailing Address: P.O. Box 231, Sumas, WA 98295

Phone: 604-853-6096 | Fax: 604-853-8749 | Internet: [www.bd-power.com](http://www.bd-power.com)

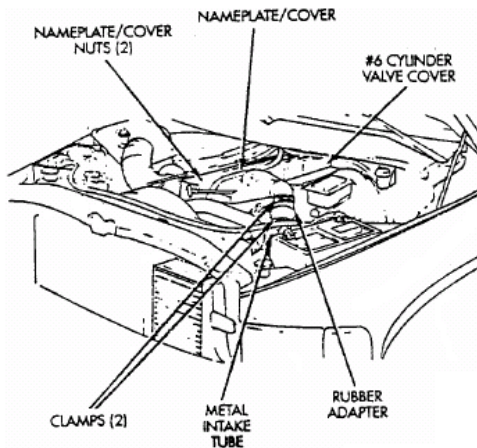

**Fig 12: Nameplate/Cover - Diesel**

2: Remove drain manifold fitting screws (bolts) at each of the six injectors (Fig 13)

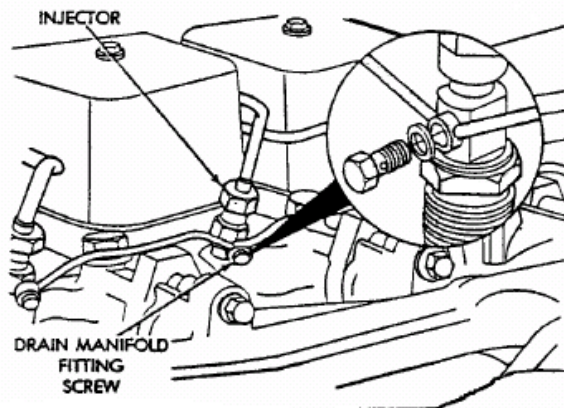

**Fig 13: Fuel Drain Manifold Fittings - Typical**

3: Remove the fuel drain manifold holddown clamp mounting bolt at the top/rear of intake manifold.  
 4: Remove the fuel drain manifold banjo fitting at the top of fuel filter/water separator (one bolt) (Fig 14).  
 5: Remove fuel drain manifold washers at each fuel injector.

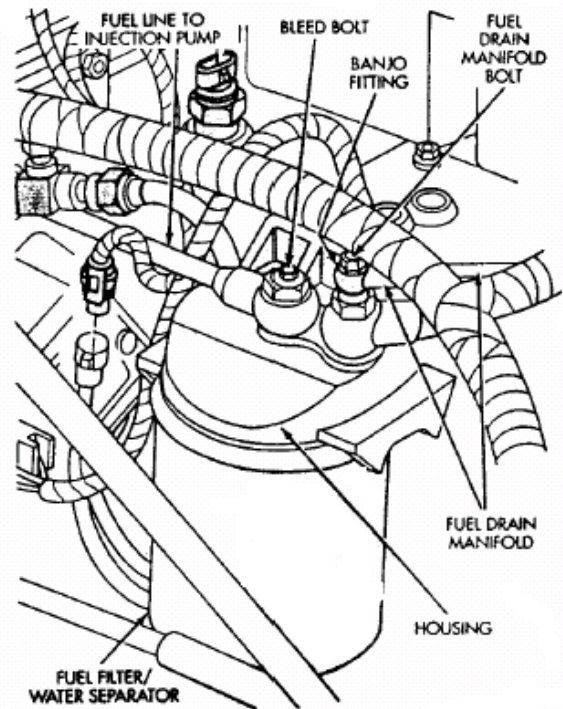

**Fig 14: Drain Manifold and Fuel Filter/Water Separator**

#### INSTALLATION:

1: Using new seals washers on all fittings, assemble fuel drain manifold in reverse order of disassembly.  
 2: Tighten drain manifold fitting screws (bolts) at the injectors to 8 N-m (6 ft. lbs) torque.  
 3: Tighten drain manifold holddown clamp screws (bolts) to 13 N-m (10 ft lbs) torque  
 4: Install nameplate/cover.

BD Engine Brake Inc.

Plant Address: 33541 MacLure Rd. Abbotsford, BC, Canada V2S 7W2

U.S. Shipping Address: 88-446 Harrison St, Sumas, WA 98295 U.S. Mailing Address: P.O. Box 231, Sumas, WA 98295

Phone: 604-853-6096 | Fax: 604-853-8749 | Internet: [www.bd-power.com](http://www.bd-power.com)