





**DOWNLOAD COLOR
INSTALL MANUALS AT
www.dieselperformance.com**





Ford 6.0L/6.4L Powerstroke Flexplate

1041240	Ford 6.4L Powerstroke
1041242	Ford 6.0L Powerstroke

1041240 Kit Contents

1401240	1401243
	
<p>Ford 6.4L Flexplate</p>	<p>Ford Flexplate Washer</p>
<p>Qty: 1</p>	<p>Qty: 1</p>

1041242 Kit Contents

1401242	1401243
	
<p>Ford 6.0L Flexplate</p>	<p>Ford Flexplate Washer</p>
<p>Qty: 1</p>	<p>Qty: 1</p>

Introduction

BD Diesel Performance Ford Flexplates were designed to withstand the high torque produced from modified Powerstroke engines. Fully billet machined and black oxide coated for good looks and performance.

- Over two times stronger than OEM
- Fully billet machined, **NO** weld on weights.
- Black oxide coating does not cause hydrogen embrittlement like zinc plating
- Correct ring gear that won't damage starter

Installation



Disconnect both batteries, and secure vehicle before installation for safety.

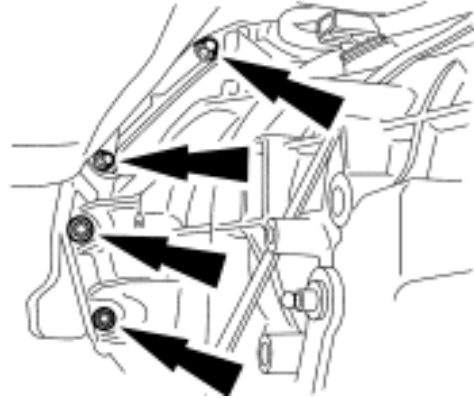

Remove transmission, and factory flexplate from the truck.

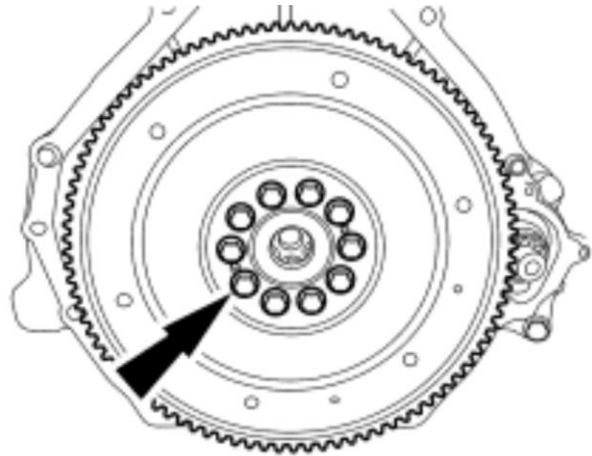

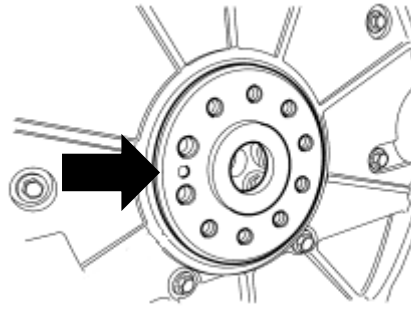

Install BD Diesel flexplate onto the crankshaft, followed by the washer.



NOTE: Ensure crankshaft dowel is fitting into the locating hole on the flexplate, and washer (see arrows)

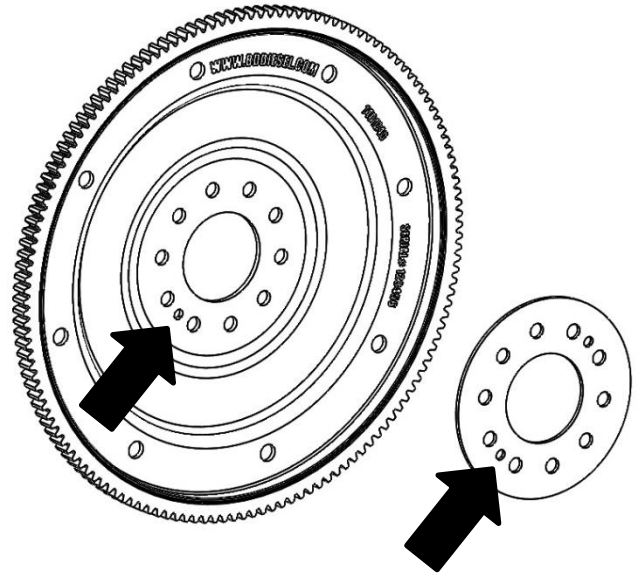

Re-install crankshaft bolts. Tighten in a two stage sequence following the order outlined in the below steps and images.

For Kit **1041242** on **6.0L Powerstroke** engines:

Torque to the below spec following the sequence in the image to the right.

1. Torque to **4 ft-lbs**
2. Torque to **69 ft-lbs**

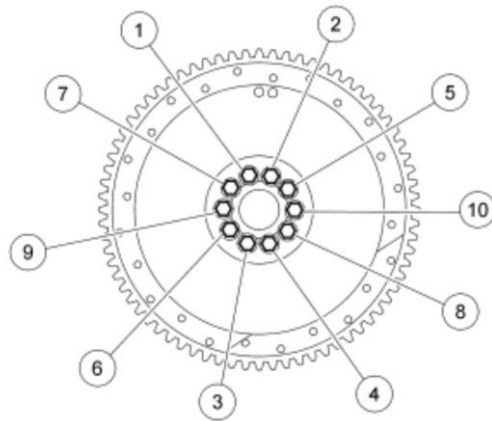

For Kit **1041240** on **6.4L Powerstroke** engines:

Torque to the below spec following the sequence in the image to the right.

1. Torque to **4 ft-lbs**
2. Torque to **69 ft-lbs**

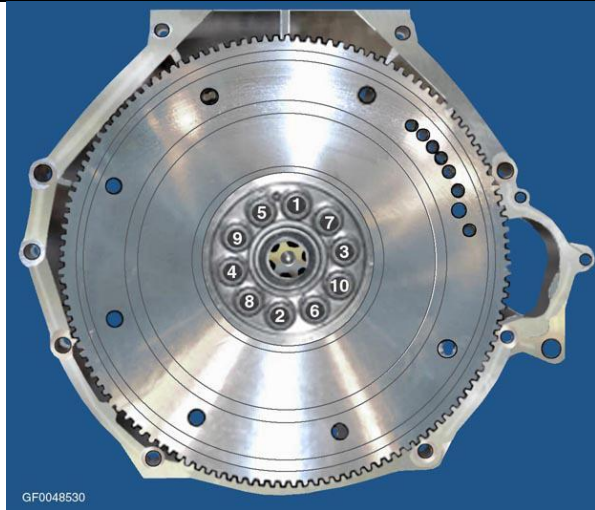

Lubricate the torque converter hub with multi-purpose grease, and re-install the transmission.

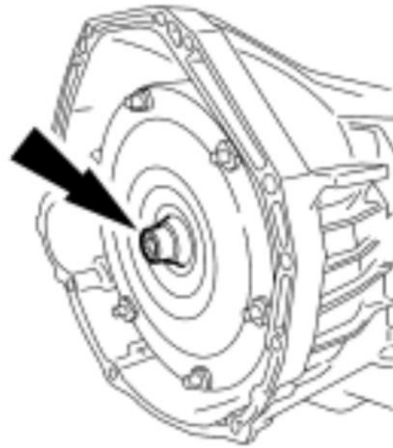

Install and torque flexplate nuts to the below specification:

Torque Converter Nuts: **35 ft-lbs**

NOTE: Do not over-torque these fasteners!

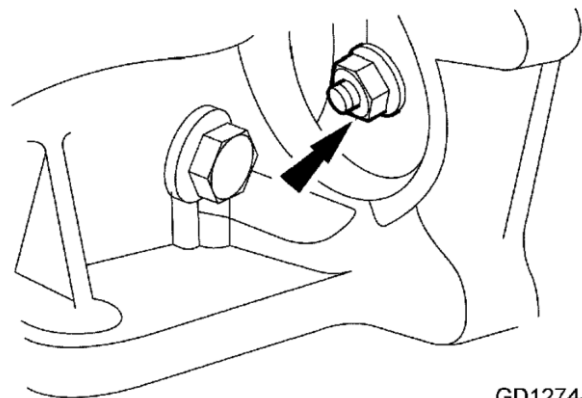

GD1274-A