

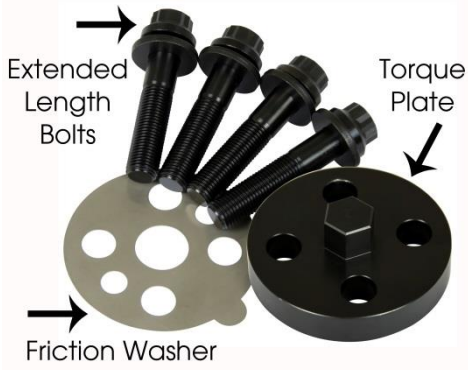

Fluidampr Cummins® Full Power Kit – P/N 300008

For Part Number 920301, 920321, 960301, 960311 & 960341 – 1992 – Present Dodge Cummins 5.9L/6.7L

It is recommended that the Fluidampr utilize our Full Power kit and drill pin kit (P/N 300002) on high horsepower Dodge Cummins 5.9L/6.7L competition drag or pulling engines in excess of 700 HP/1,250 Ft. Lbs. of torque and 3500 RPM.



| Included With Kit | | |
|----------------------------|----------------|----------|
| Description | P/N | Quantity |
| 12mm x 2.225 12 Point Bolt | M14AU2_225-1 | 4 |
| Bolt Washer | PCWASHER12MMHS | 4 |
| Crankshaft Friction Washer | 960341-FW01 | 1 |
| Torque Plate | 960341-TP01 | 1 |

Fluidampr recommends using drill pin kit P/N 300002 to pin the Fluidampr to the crankshaft prior to installing the Full Power Kit. The drill pin kit helps to prevent bolt fretting. If using drill pin kit, before tapping dowel pin(s) in damper make sure to install crankshaft friction washer between crankshaft and damper.

After the Fluidampr has been successfully pinned, ensure that the dowel pin(s) are flush/below flush with the damper face.

Prior to bolt installation, install the washers onto the bolts with the chamfered side facing the bolt head, lubricate threads, under washer and between head & washer. Install torque plate and extended length bolts hand tight per diagram below.

Tighten and torque bolts to **125 Ft-Lbs.** (Fluidampr does not recommend the use of an impact wrench to tighten)

The torque plate also incorporates a 5/8" hex to be used as a barring tool to assist in turning the engine over by hand.

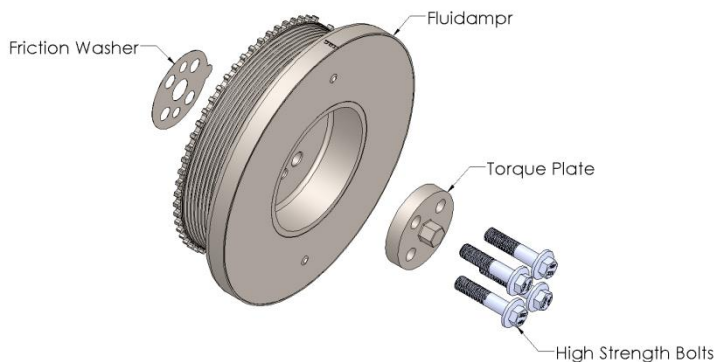

*****IMPORTANT*****

After installation, check clearance from damper to timing cover. If contact is made, Contact Fluidampr Tech Service to review. (716) 592-1000 or sales@fluidampr.com

RE-TORQUE damper bolts after initial warmup cycle once installation is complete.

Fluidampr recommends in applications over 700HP to recheck torque after every run or pull.

Check crankshaft thread depth to ensure proper bolt length prior to installation. With damper removed, thread bolts into crankshaft fully with washer installed. Space between washer and crankshaft should be less than the Fluidampr mounting flange thickness. Minimum thread engagement = 0.75".

If you have any questions please contact Fluidampr customer service at
 Fluidampr – 180 Zoar Valley Road, Springville, NY 14141
 Ph: 716-592-1000 – Email: support@fluidampr.com